

Item No.:FJ3051

<http://www.freewing-model.com>

Instruction Manual

Stinger 90

EN	1
中	16



WINGSPAN : 1130mm (44.49 in)

Version No.:FJ3051-V01

Freewing Model Co.,Ltd
<http://www.freewing-model.com>

  
MADE IN CHINA

Thanks for your purchasing our Freewing "Stinger 90". It is a new 90mm EDF sport jet, we revised it on the basis of Stinger 64's shape.

Stinger 90 used many excellent design, seamless flap design and seamless aileron design, let the foam surface looks more clean and beautiful. 17g metal gear servos, new surface control horns and clevis, let the surface control more precise and stable. New multi-propeller ducted fan, can produce more thrust and better voice. New LED taxi light, give the players a new visual enjoyment.

⚠ NOTE: This is not a toy. Not for children under 14 years. Young people under the age of 14 should only be permitted to operate this model under the instruction and supervision of an adult. Please keep these instructions for further reference after completing model assembly.

Note

1. This is not a toy! Operator should have a certain experience, beginners should operate under the guidance of professional players.
2. Before install, please read through the instructions carefully and operate strictly under instructions.
3. Cause of wrong operation, Freewing and its vendors will not be held responsible for any losses.
4. Model planes' players must be on the age of 14 years old.
5. This plane used the EPO material with surface spray paint, don't use chemical to clean, otherwise it will damage.
6. You should be careful to avoid flying in areas such as public places, high-voltage-intensive areas, near the highway, near the airport or any other place where laws and regulation clearly prohibit.
7. You cannot fly in bad weather conditions such as thunderstorms, snows....
8. Model plane's battery, don't allowed to put in everywhere. Storage must ensure that there is no inflammable and explosive materials in the round of 2M range.
9. Damaged or scrap battery should be properly recycled, it can't discard to avoid spontaneous combustion and fire.
10. In flying field, the waste after flying should be properly handled, it can't be abandoned or burned.
11. In any case, you must ensure that the throttle is in the low position and transmitter switch on, then it can connect the lipo-battery in aircraft.
12. Do not try to take planes by hand when flying or slow landing process. You must wait for landing stop, then carry it.

Assembling data index

Product Basic Information	2
Package list	2
Installing the Wing	3
Installing nose landing gear	6
Installing rear landing gear	7
Installing servo	7
Installing Battery	9
Center of Gravity	9
Install power system & motor parameters	10
Control direction test	12
Control surface rate	13
Troubleshooting Guide	14
Accessories list support	15

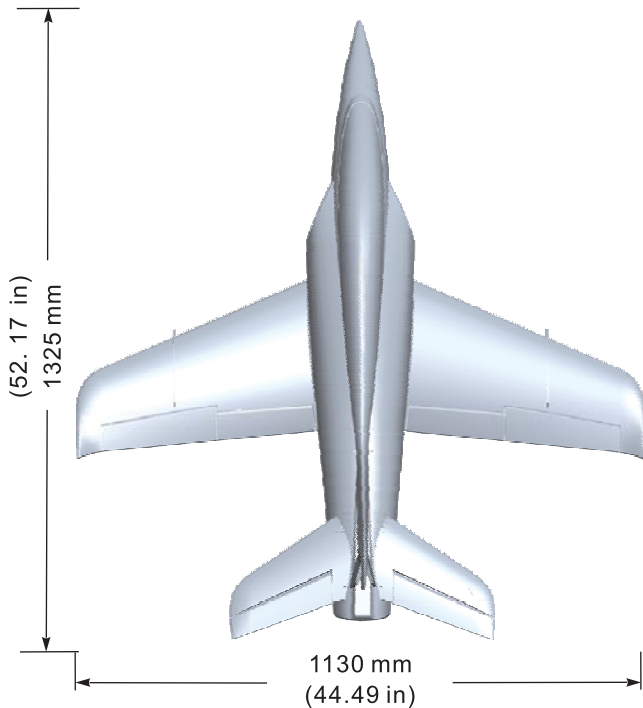

- Motor
3748-1450KV
- ESC
100A ESC (UBEC 8A)
- Servo
9g Metal Gear Servos (2pcs)
17g Metal Gear Servos (7pcs)
- Battery
6S 22.2V 5000mAh 35C
1S 3.7V 450mAh 25C (1pcs Use for LED Lights)
- Ducted Fans
90mm EDF
- Take-off weight
2800g (98.8 oz.) (Use Freewing Battery-6S 22.2V 5000mAh 35C)
- Thrust
3200g (113 oz.)

Note: The parameters in here are derived from test result using our accessories. If use other accessories, the test result will be different. Any problem since of using other accessories, we are not able to provide technical support.

Landing Gear	Aileron	Flaps	Elevator	Rudder	Throttle
Yes	Yes	Yes	Yes	Yes	Yes

Package list



Open package and check the package list. (Different version include different contents)

No.	Accessories Name	ARF	PNP	KIT
1	Fuselage set	Yes	Yes	Yes
2	Main wing set	Yes	Yes	Yes
3	Tail wing set	Yes	Yes	Yes
4	Nose Cone (2pcs)	Yes	Yes	Yes

No.	Accessories Name	ARF	PNP	KIT
5	Battery	Yes	No	No
6	Y Wire	Yes	Yes	Yes
7	Carbon fiber tube	Yes	Yes	Yes
8	Screwdriver & screw accessories	Yes	Yes	Yes

Remove these accessories

- A- Fuselage
- B- Left/Right wing
- C- Carbon tube
- D- Screw PWM3*6 2pcs
- E- Screw PM3*40 4pcs
- F- Y-wire

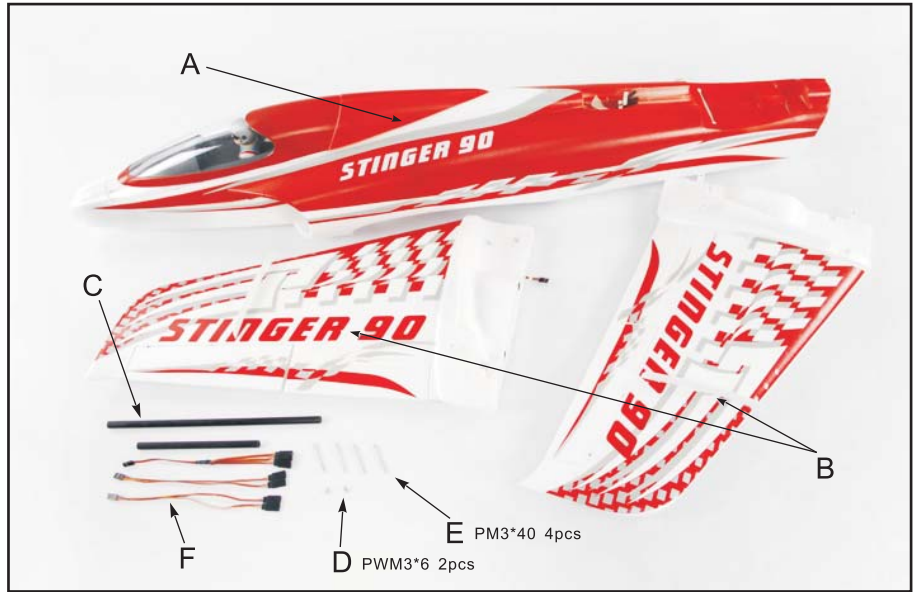

1. Insert the carbon tube (C) into fuselage.
2. Insert the left/right wing into together.
3. Screw tightly by screws(D).

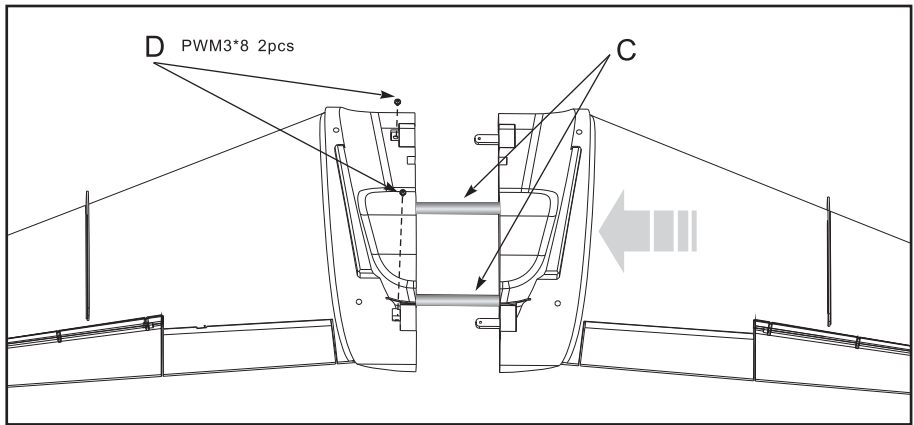

4. Connect the aileron servos by Y wire(F). Connect the flap servos by Y wire(F).
5. As the right photo shown, along the arrow direction ,Y wire (F) penetrates from the fuselage(G) into canopy.
6. Install the main wing on the fuselage and fix it by 4 screws(E).

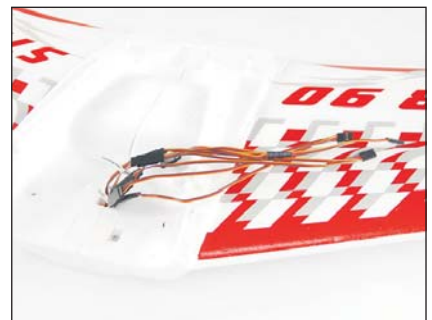
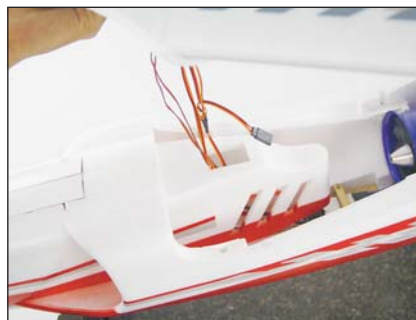
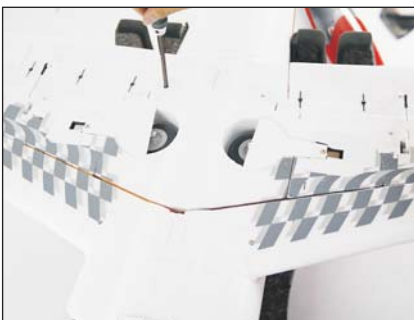
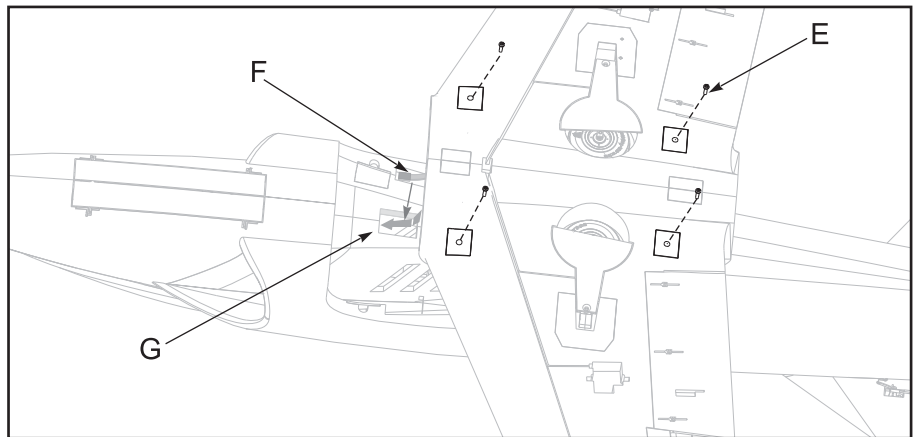

Remove these accessories and continue to install.

A- The fuselage which installed on the wing

B- Elevator

C- Screw PA3*25 4pcs

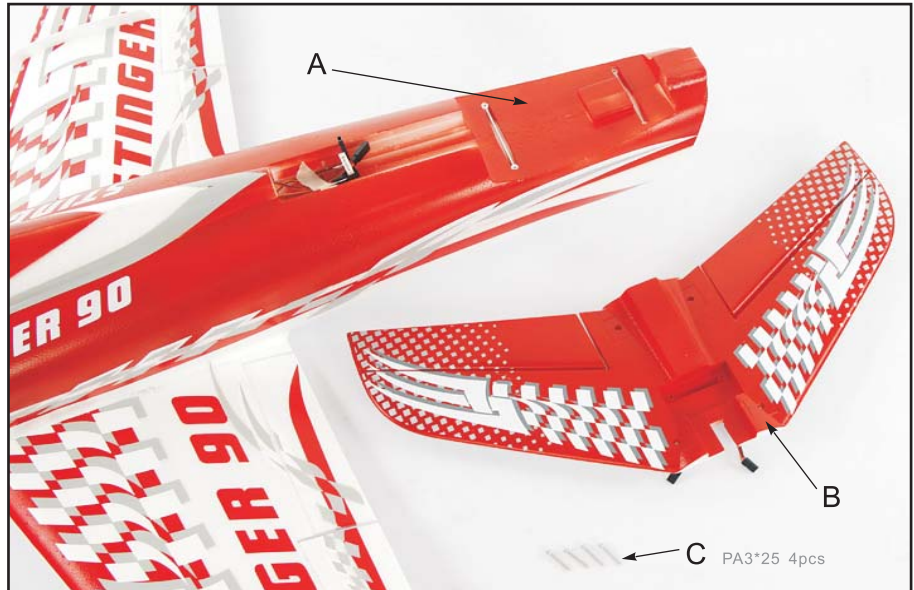

1. Connect the elevator servos cable (D) by Y-wire (E).

2. Install the elevator in the fuselage. When install the elevator, you should insert the extra long servo cable into the trough (F) of fuselage.

3. Fixed the elevator by screws (C).

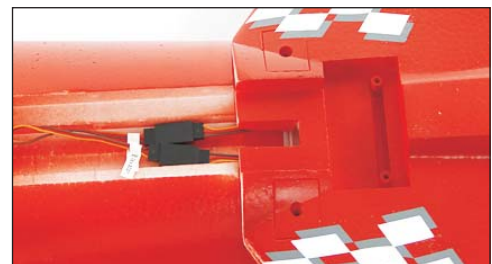
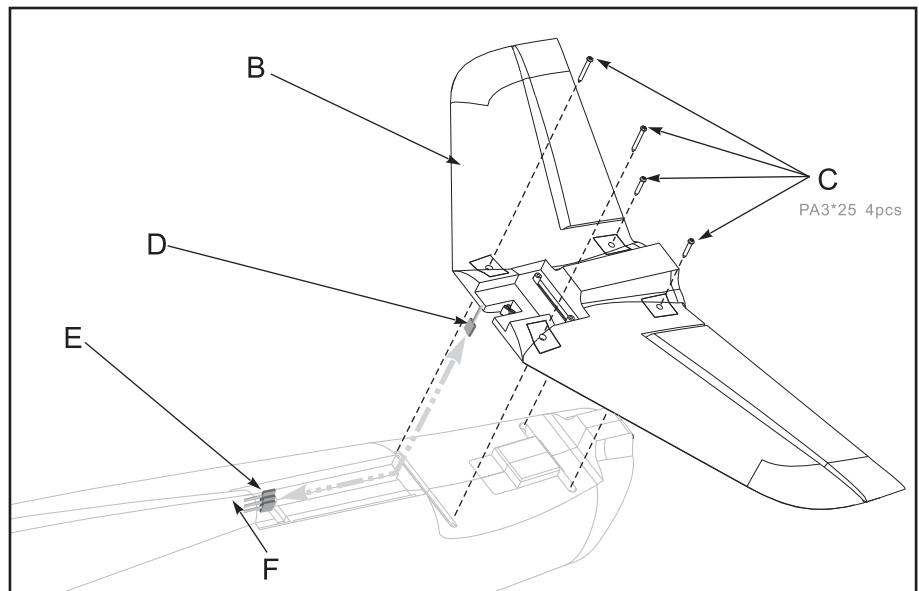

Installing the rudder

EN

Remove these accessories.

- A- Fuselage
- B- Rudder
- C- Screw PA3*25 4pcs

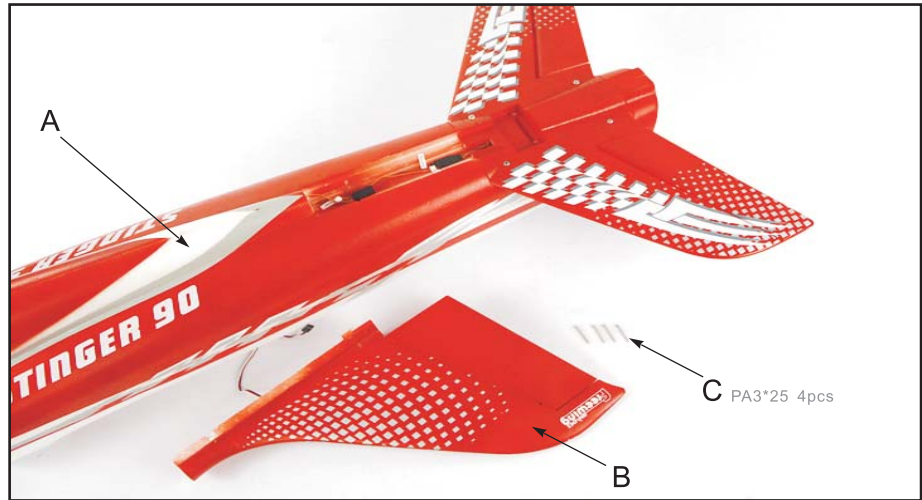

1. Connect the rudder servo cable (F) and extension wire (G) in fuselage.
2. Install the rudder on the fuselage. When install the rudder, you should insert the extra long servo cable into the trough (G) of fuselage.
3. Install the "V" shape rudder plastic part (C) on the rudder.
4. Fixed the elevator by screws (E) (D).

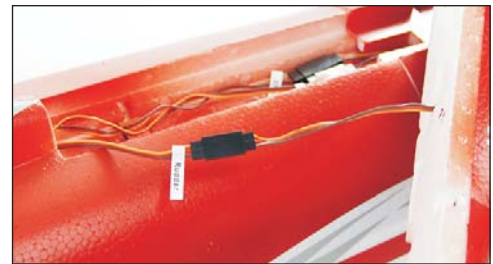
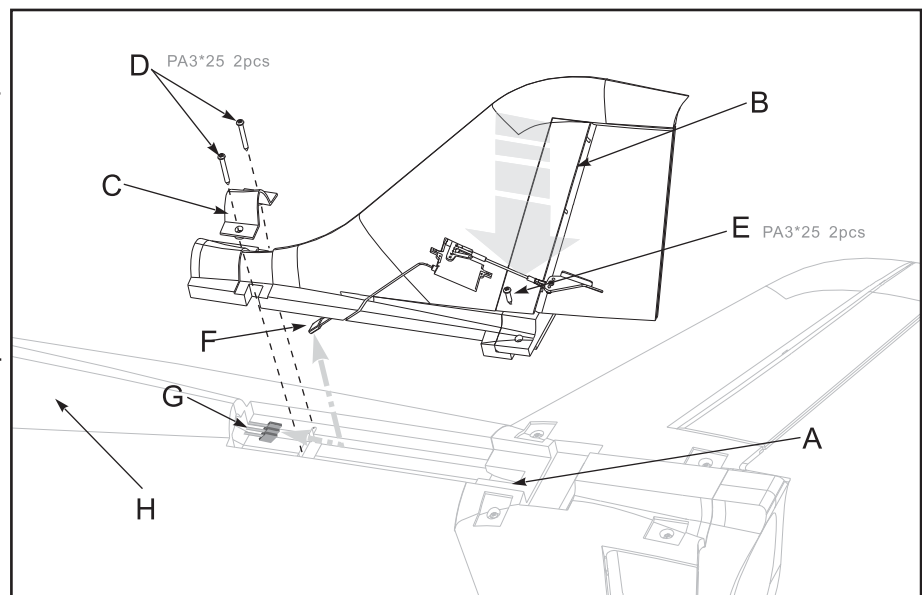

Installing nose cone

We prepared two pcs nose cone for you, one of them is a gift with free charge. We remove one nose cone to install.

- A- nose cone
- B- screw PWA3*8 2pcs

As the right photo shown, insert the nose cone A into the head of fuselage, then fix it with screws (B).

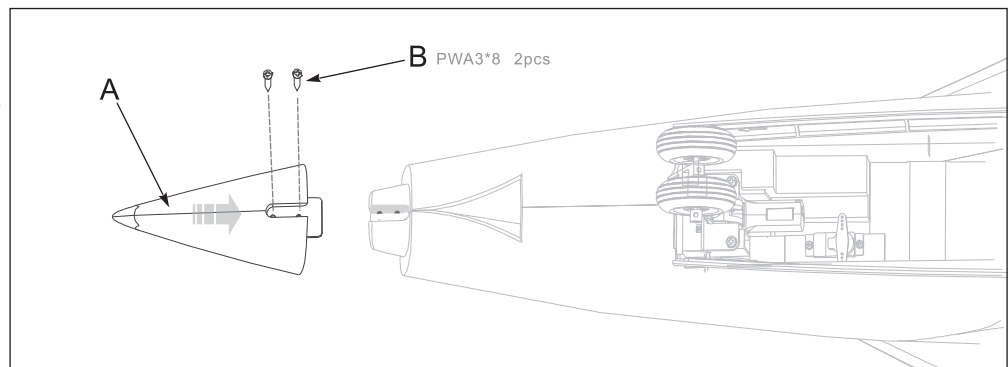

Usually, before ship, the factory installed all the landing gear. In here, we also need to provide more details installation and spareparts name. Players can refer it to revise and replace parts.

Nose landing gear sparepart list:

A-Landing gear electric base	N-Screw
B-Landing gear rotating arm	O-Spring
C-E buckle	P-Damping active lever
D-Nose landing gear metal wire	Q-Screw
E-Nose landing gear steering wire	R- "8" shape damping shaft
F-Nose landing gear steering arm	S-Pin
G-Screw	T-E buckle
H-Nose landing gear main strut	U-Slant supporting rod
I-Jimi screw	V-Wheel
J-Trough	W-Wheel shaft
K-Take-off light	X-Gasket
L-Screw	Y-Jimi screw
M-U shape damping arm	Z-Metal sleeve
	AB-Jimi screw
	AC-Landing gear installed set
	AD-Nose gear mount
	AE-Screw

1. Disassemble the landing gear electric base (A) and remove the landing gear rotating arm (B).
2. Insert the nose landing gear metal wire (D) into the landing gear rotating arm (B), then use E-buckle (C) to stuck in the lower end of the nose landing gear metal wire (D), to avoid the wire off.
3. Put nose landing gear steering arm (F) into the nose landing gear metal wire (D), then use one screw (G) to fix it on the nose landing gear metal wire (D). Finally screw the nose landing gear steering wire (E) on the nose landing gear steering arm (F).
4. Put the nose landing gear main strut (H) on the nose landing gear metal wire (D), use 2 pcs screws (J) to fix. Use 502 glue to attach the trough (J) on the nose landing gear main strut (H).then use screw (L) to fix the take-off light (K) on the nose landing gear main strut (H) and put the take-off light wire into the trough (J).
5. Put the U- shape damping arm (M) into the nose landing gear main strut (H) and use 1 pcs screw (N) to fix.
6. Put the Spring (O) into the nose landing gear main strut (H), and then put the damping active lever (P) into the nose landing gear main strut (H), and lock the screw (Q) on the nose landing gear main strut (H).
7. Put the "8" shape damping shaft (R) into the U- shape damping arm (M), then insert 1pcs pin (S) and use E-buckle (T) to fix.
8. Put one side of slant supporting rod (U) into "8" shape damping shaft (R), then insert 1pcs pin (S) and use E-buckle (T) to fix. Put another side into the top of the damping active lever (P),

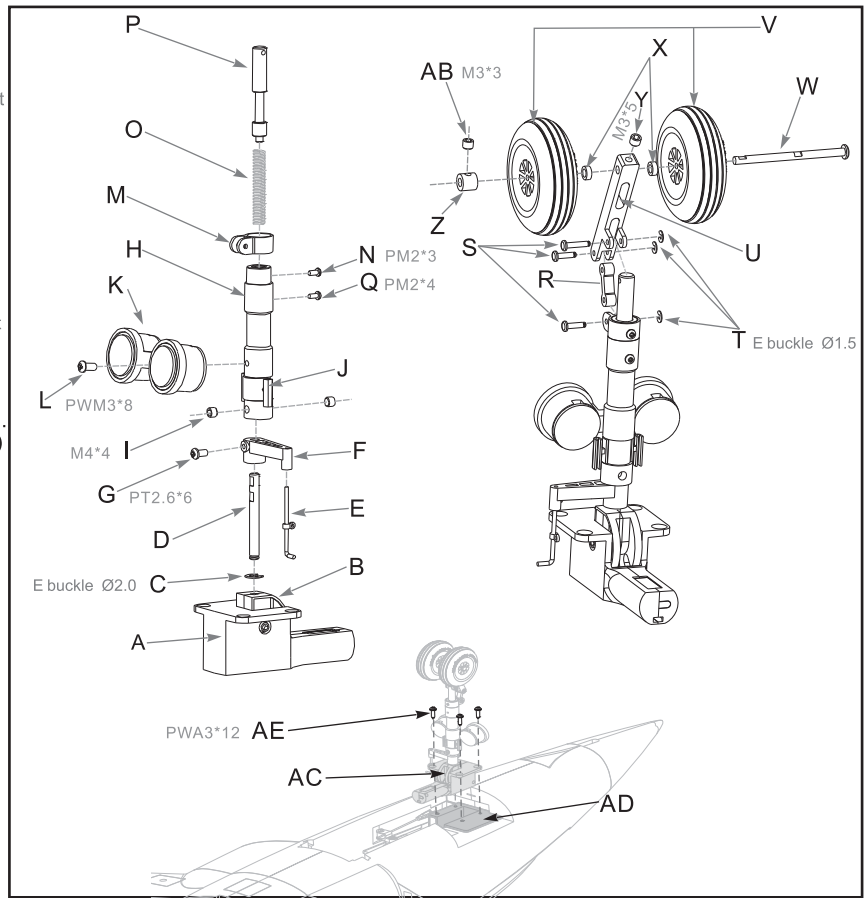

9. Put the wheel (V) into wheel shaft (W), then put the gasket (X) into wheel shaft (W), together with wheel shaft (W), wheel (V), gasket (X), into the slant supporting rod (U) and use 1 pcs screw (Y) to fix.
10. Put another gasket (X) into wheel shaft (W) and put the wheel (V) into wheel shaft (W), finally put the metal sleeve (Z) and use Jimi screw (AB) to fix.

11. Assemble the landing gear installed set (AC) on the nose gear mount (AD) and use 4pcs screws (AE) to fix.

Note: When installing, please check the flat position of spareparts, when screw to fix, the flat position must fact to the screw hole, just like this, it can fix successfully, the spareparts don't rotate and fall off.

Note: There are spareparts name and its material code in manual, if you need to purchase spareparts, please refer it and consult with local distributor.

Installing the servo of nose landing gear steering

Spare part name

A-9g metal gear servo
B-Screw
C-Screw
D-Screw
E-U-shape servo arm
F-Servo pushrod
G-Landing gear steering control ring

1. Installed the servo (A) on the wood piece, and use screw (B) to fix the servo. Then installed the U-shape servo arm (E) on the servo (A) and fixed it by screw (C).
2. Bucked one side of servo pushrod (F) into landing gear steering control ring (G). Insert another side into U-shape servo arm (E), adjust to be centered.
3. Use screw (D) to fix the pushrod (F)

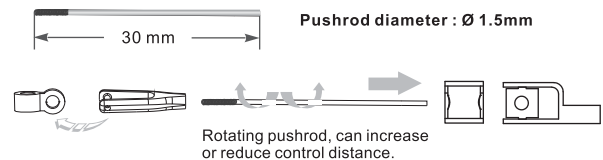

The servo mount parameter of nose landing gear steering

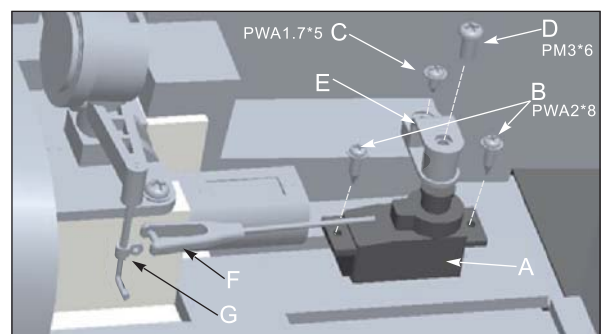
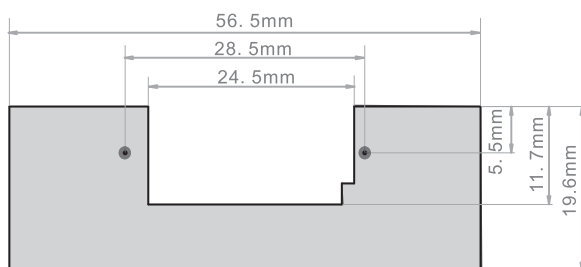

Rear landing gear sparepart list:

- A-Landing gear rotating arm
- B- jimi screw
- C-Rear landing gear metal wire
- D-Rear landing gear main strut
- E-Screw
- F-Spring
- G-Rear landing gear damping active lever
- H-Pin
- I-Rear landing gear cabin cover
- J-Jimi screw
- K-Wheel shaft
- L-Wheel
- M-Gasket
- N-Jimi screw
- O-Rear landing gear installed set
- P-Rear gear mount
- Q-Screw
- R-"U" shape blister piece

- 1.Insert the rear landing gear metal wire (C) into landing gear rotating arm (A) and fix it by 2pcs jimiscrews(B).
- 2.Put the rear landing gear main strut (D) into rear landing gear metal wire(C) and fix it by screw (E).
- 3.Put the spring (F) in the rear landing gear main strut (D), then put the rear landing gear damping active lever (G) into the rear landing gear main strut (D) and press it down firmly and press the pin (H) to the hole of the rear landing gear damping active lever (G).
- 4.Put the wheel (L) to the wheel shaft (K), then put the gasket (M) to the wheel shaft (K), finally penetrate the wheel shaft (K) to the hole of the rear landing gear damping active lever (G). Use jimiscrew (J) to fix.
- 5.Put rear landing gear cabin cover (I) on the rear landing gear main strut (D) and fixed it with screw (J).

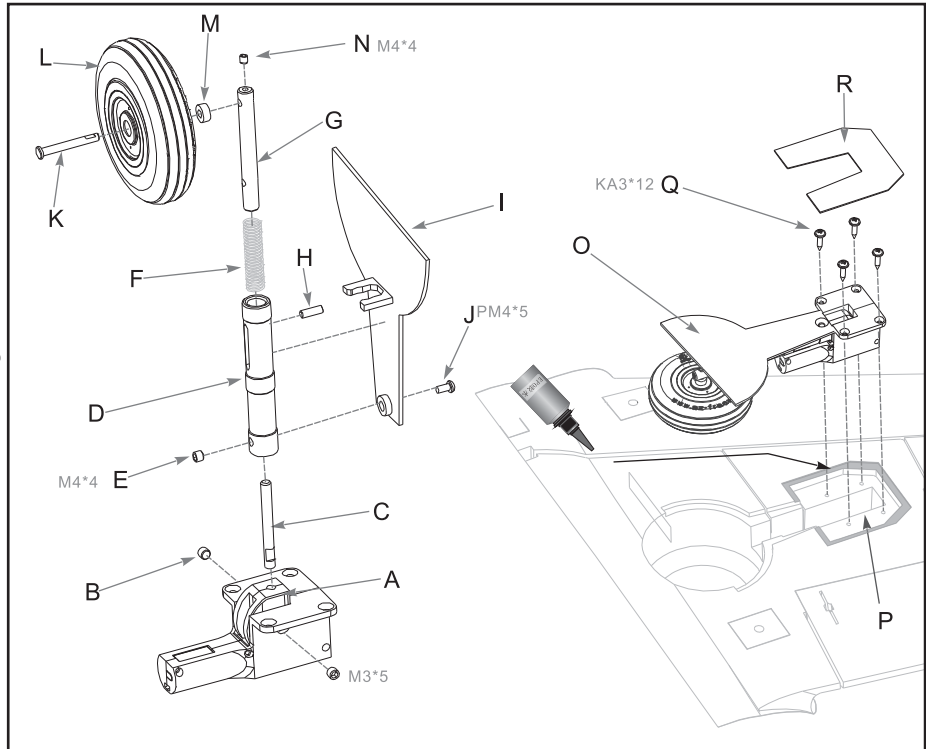

- 6.Assemble the landing gear installed set (O) on the rear gear mount (P) and fix it with 4pcs screws (Q).
- 7.Attached the glue on the indicated place, and attach the U-shape blister piece (R) on the main wing.

Note: When installing, please check the flat position of spareparts, when screw to fix, the flat position must fact to the screw hole, just like this, it can fix successfully, the spareparts don't rotate and fall off.

Note: There are spareparts name and its material code in manual, if you need to purchase spareparts, please refer it and consult with local distributor.

Installing the servo of main wing

- 1.Attached the glue on the indicated place, and attached the 17g servo box (B) and control surface horn (A) on the main wing.
- 2.Press the 17g servo (C) in the servo box (B), and press the servo cable (G) in the trough (H) on the wing.
- 3.Put the servo cover (D) on the servo box (B), fix it with 2 pcs screws(E).
- 4.Connect the control horn and servo arm by servo pushrod(F).
- 5.Adjusted the control surface to be centered.

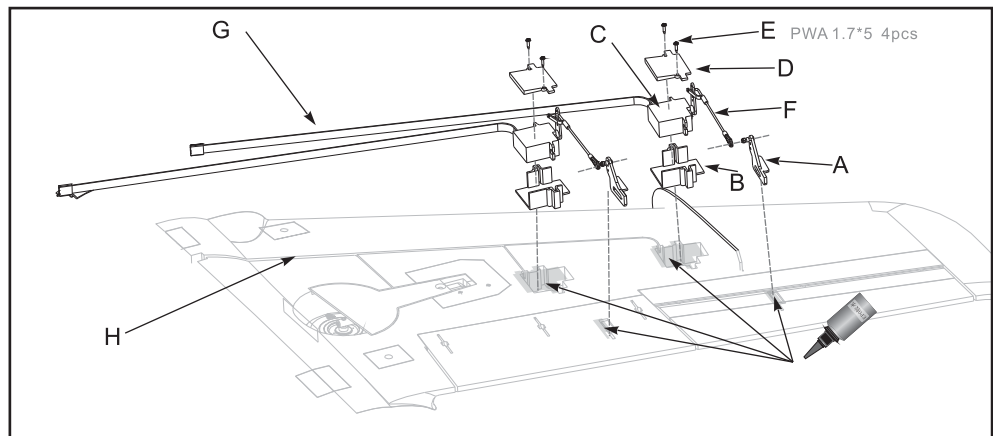

Note: we have installed all the servo box in aircraft, when players disassemble the servo, it will not damage the foam surface. If need to replace servo, please purchase Freewing servo, or refer to the following drawing, choose the correct size servo.

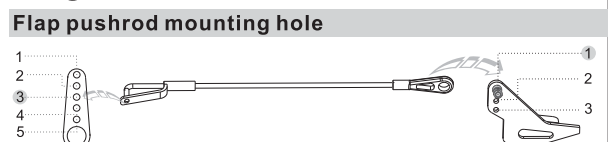
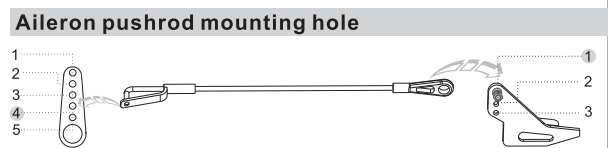
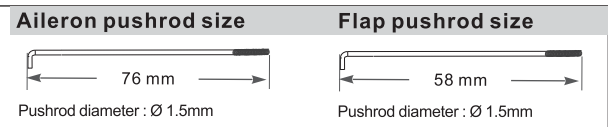
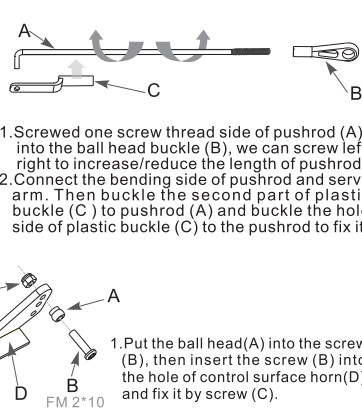
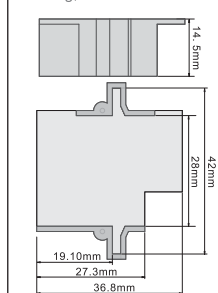

1. Apply glue on the indicated area as the right photo shown, and attach the 17g servo box (A) and control horn (B) on the main wing.
2. Press the 17g servo (C) on the servo box (A), and press the servo cable (D) on the trough (G) of main wing.
3. Put the servo cover (E) on the servo box (A) and fix it by 2pcs screws(F).
4. Connect the servo arm and control horn by servo pushrod (H).
5. Center the servo arm.
6. Use the same way to install another elevator servo and rudder servo.

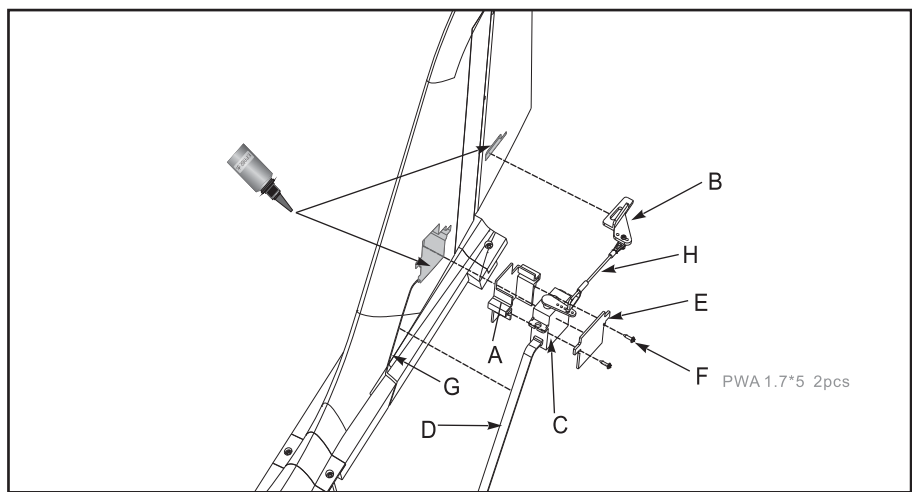
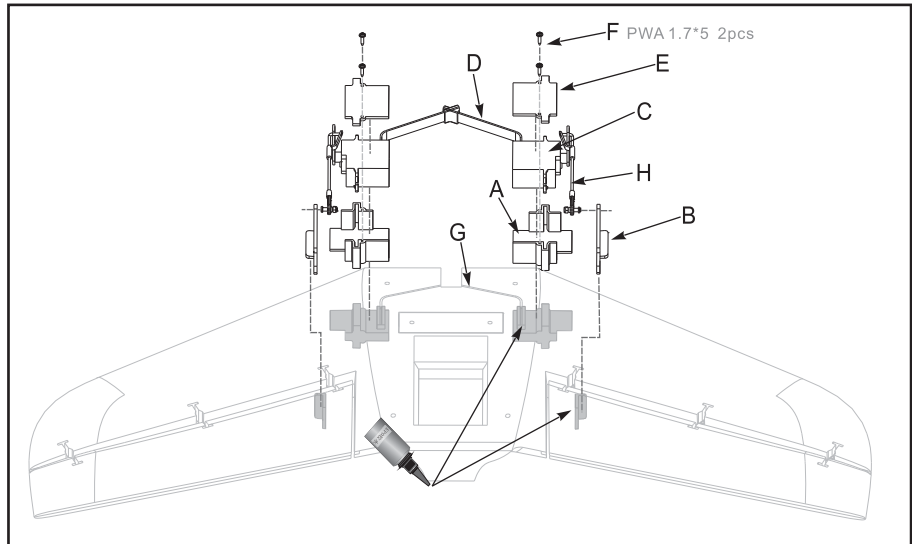

Note: we have installed all the servo box in aircraft, when players disassemble the servo, it will not damage the foam surface. If need to replace servo, please purchase Freewing servo, or refer to the following drawing, choose the correct size servo.

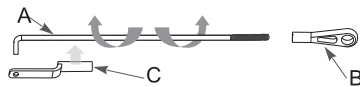

1. Screwed one screw thread side of pushrod (A) into the ball head buckle (B), we can screw left, right to increase/reduce the length of pushrod.
2. Connect the bending side of pushrod and servo arm. Then buckle the second part of plastic buckle (C) to pushrod (A) and buckle the hole side of plastic buckle (C) to the pushrod to fix it.

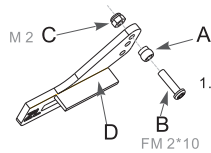
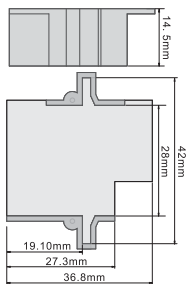

1. Put the ball head(A) into the screw (B), then insert the screw (B) into the hole of control surface horn(D), and fix it by screw (C).

Elevator pushrod size

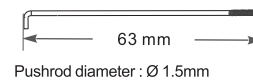

Rudder pushrod size

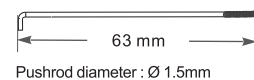

Elevator pushrod mounting hole



Rudder pushrod mounting hole



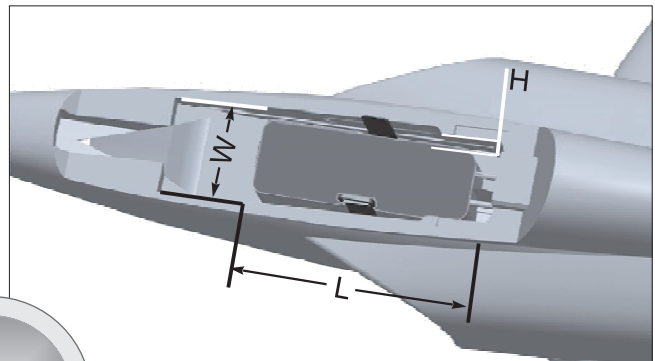
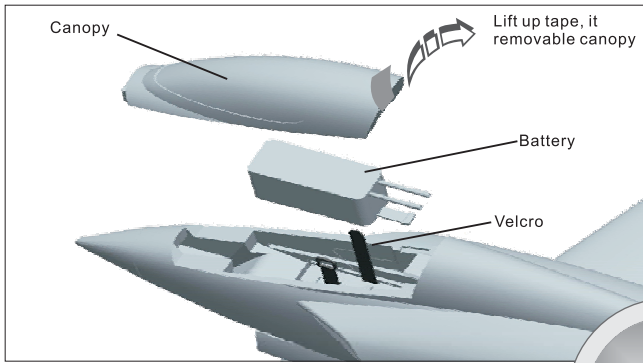

Lift up tape, it removable canopy, then bundled battery with Velcro.

Before connect battery and receiver, please switch on the transmitter and check that the throttle is in the low position.

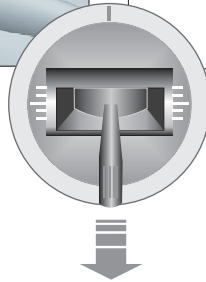

Our standard battery is: **6S 22.2V 5000mAh 35C**
You can choose the battery refer to the battery cabin size:

L=180mm; W=60mm; H=48mm

6S 22.2V 3200mAh ~ 6S 22.2V 5500mAh
Discharge rate of C > 35C

Different weight battery may affect its CG, please the correct range of CG indication.

Center of Gravity

Correct center of gravity is directly related to the success of the flight, please refer to the following CG diagram to adjust your plane's center of gravity.

- You can move the battery forward or backward to adjust the center of gravity.
- If you can not adjust the CG through move the battery, you can also use some other suitable material weight to counterweight, to make sure that CG is in the correct position.

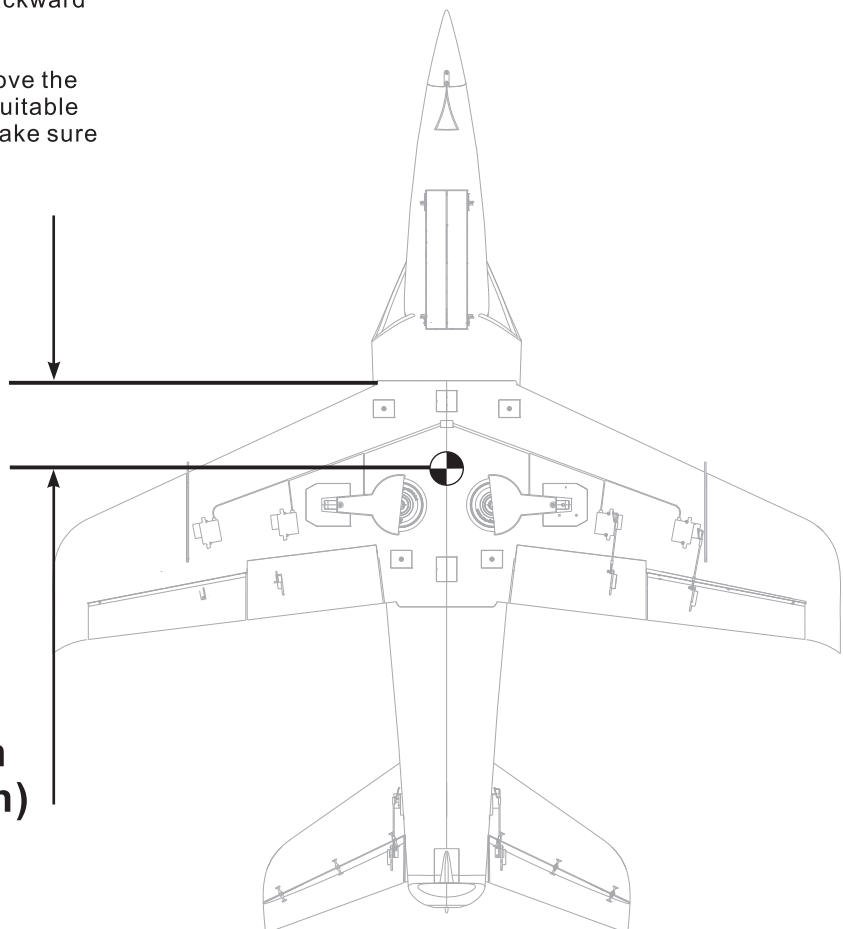

1. Installed the motor (D) in the ducted fan cover (C).
2. Fixed it with 4pcs cup head screws (B).
3. Put the fan (E) into motor shaft. (please note the plat position of hardware which installed in the fan, and the plat position of motor shaft, please check the alignment to install together.
4. Use the spinner (F) cover the fan, and use the cup head screw (G) to fix the spinner (F).
5. Finally install the fan cowl (A) on the bottom of ducted fan cover (C) and fix it with 2 pcs jimis screws (H).
6. Connect the motor and ESC in fuselage.
7. Put the installed EDF(I) in the fuselage (K).
8. Use 6pcs screws (J) to fix the installed EDF(I) on the wood piece.

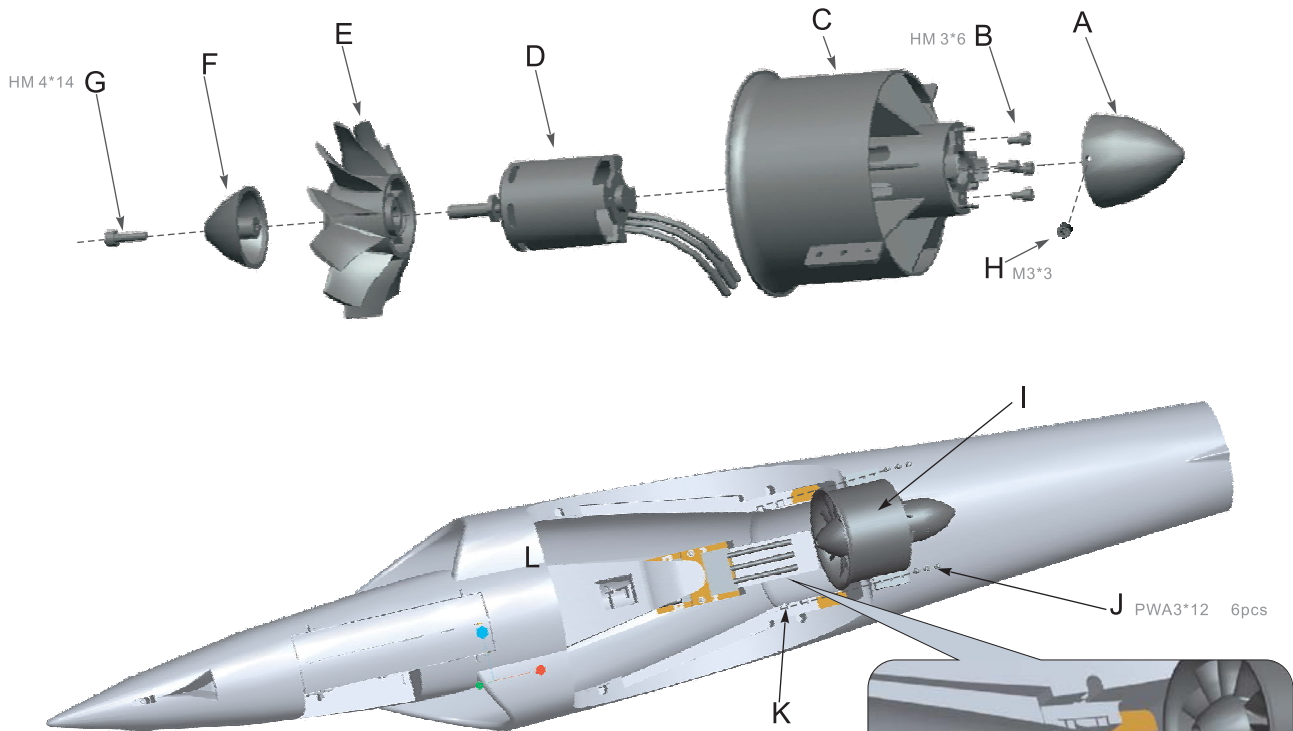

Note: When ESC and battery connected, prohibit to touch them by hand to avoid accidental injury. When test EDF, please use safety test stand for testing, prohibit to touch by hand for testing.

Note: When test EDF, if the motor reverse to turn, we can exchange the connection of wire 1 and wire 3 to change the motor's rotation.

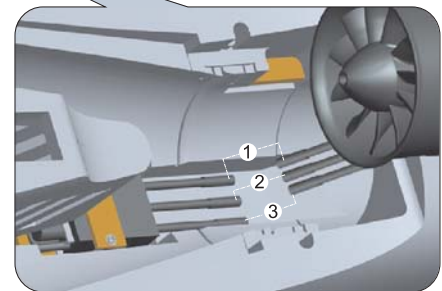

Motor parameters

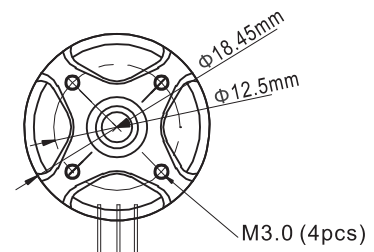
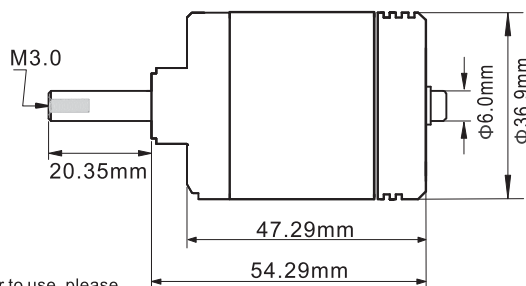
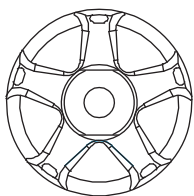

Note: If you need other motor to use, please refer to the dimension shown on the left to select your motor, to make sure that the motor you purchased can install successfully.

Item No.	KV Value	Voltage (V)	Current (A)	Pull (g)	Motor Resistance	Weight (g)	No Load Current	Propeller	ESC
MO03712	1450RPM/V	22.2	80	3600	0.02 Ω	195	2.7A/10V	90mm Ducted Fan	≥ 95A

1. Installed the motor (A) in the ducted fan cover (B).
2. Fixed it with 4pcs cup head screws (C).
3. Put the clip (E) into motor shaft and use 4pcs jimis screws(D) to fix the clip (E).
4. Put the fan (F) into the clip (E). (please note the plat position of hardware which installed in the fan, and the plat position of motor shaft, please check the alignment to install together.
5. Cover the spinner G on the top of fan(F),and use cup head screw (H) to fix the spinner G

6. Finally install the fan cowl (A) on the bottom of ducted fan cover (C) and fix it with 2 pcs jimis screws (H).
7. Connect the motor and ESC in fuselage.
8. Put the installed EDF(I) in the fuselage.
9. Put the EDF fixed ring (J) in the groove of outer surface of ducted fan cover, and use 6pcs screws (J) to fix the installed EDF(I) on the wood piece(L).

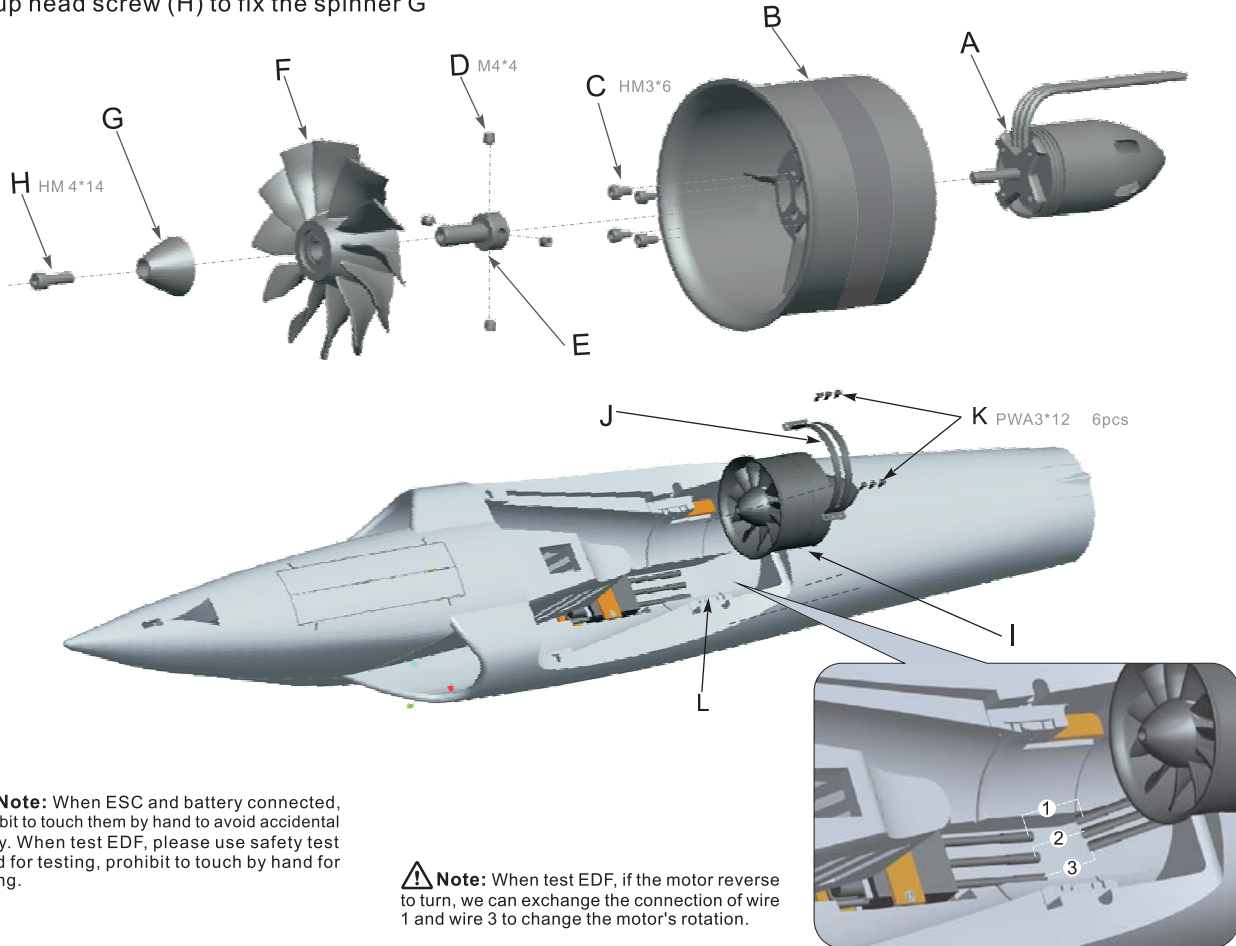

⚠ Note: When ESC and battery connected, prohibit to touch them by hand to avoid accidental injury. When test EDF, please use safety test stand for testing, prohibit to touch by hand for testing.

⚠ Note: When test EDF, if the motor reverse to turn, we can exchange the connection of wire 1 and wire 3 to change the motor's rotation.

Motor parameters

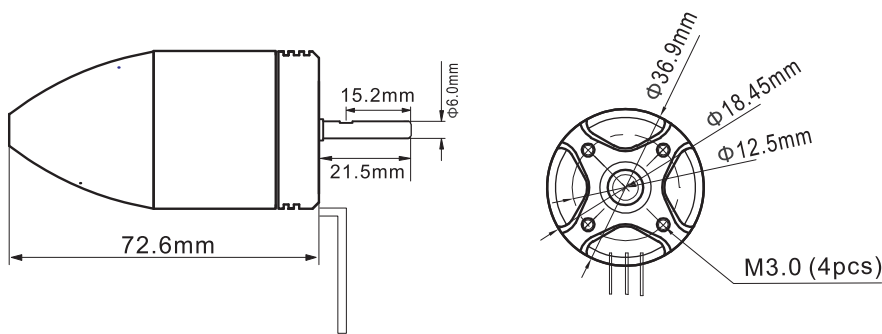

⚠ Note: If you need other motor to use, please refer to the dimension shown on the left to select your motor, to make sure that the motor you purchased can install successfully.

Item No.	KV Value	Volate (V)	Current (A)	Pull (g)	Motor Resistance	Weight (g)	No Load Current	Propeller	ESC
MO03711	1450RPM/V	22.2	83	3400	0.02Ω	195	2.7A/10V	90mm Ducted Fan	≥ 95A

After installed the plane, before flying, we need a fully charged battery and connect to the ESC, then use radio to test and check that every control surface work properly.

Aileron

Stick Left

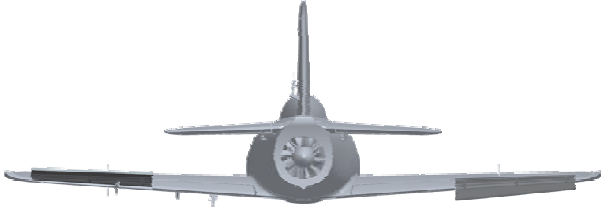

Stick Right

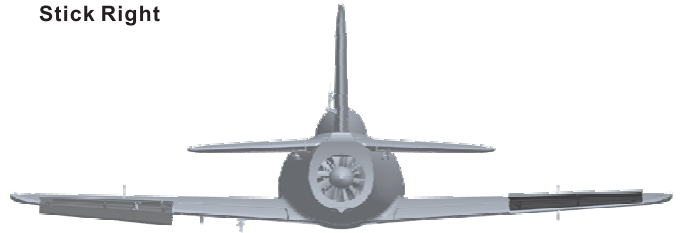

Elevator

Up Elevator

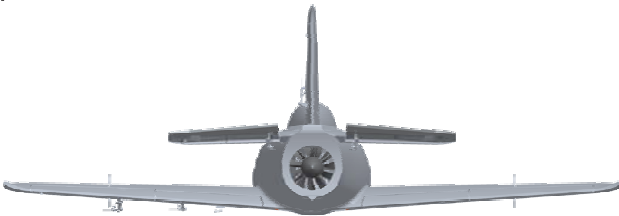

Down Elevator

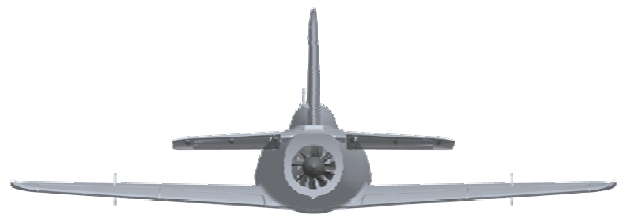

Rudder

Stick Left

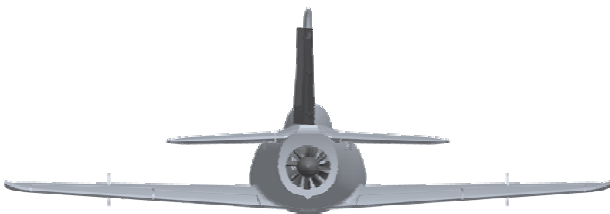

Stick Right



Optional Flaps

Flaps down

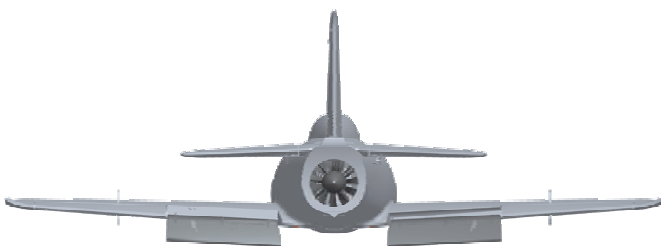

According to our testing experience, according to the following parameters to set the aileron/elevator rate, it will be useful for flight. In low rate, its good for flight control and its suitable for the initial flight or less skilled players. According to your own circumstance, choose one rate in flight.

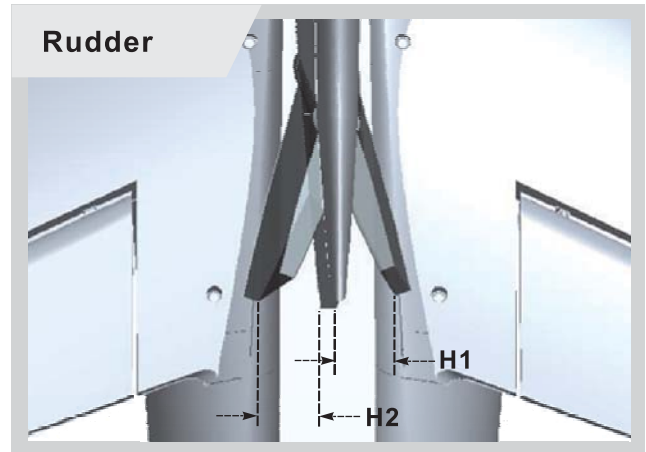
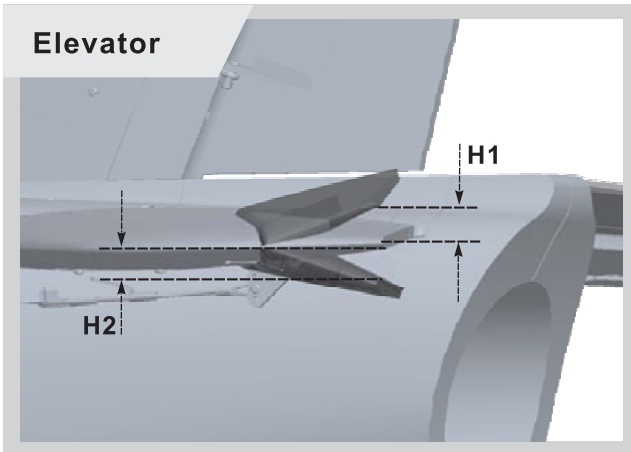
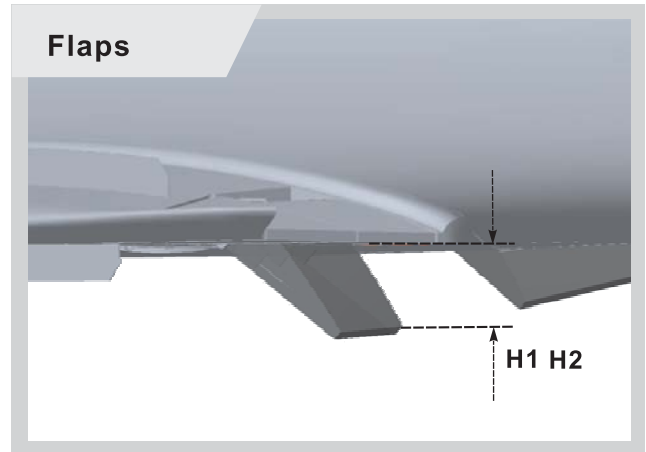
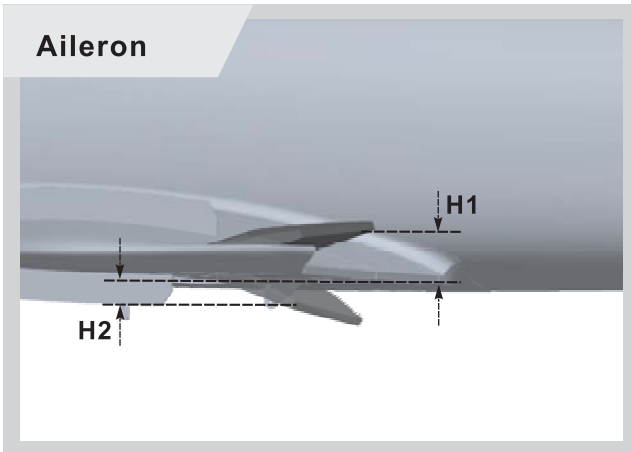

	Aileron	Flaps	Elevator	Rudder
Low Rate	H1/H2 14mm / 14mm	H1 35mm	H1/H2 15mm / 15mm	H1/H2 20mm / 20mm
High Rate	H1/H2 20mm / 20mm	H1 55mm	H1/H2 22mm / 22mm	H1/H2 30mm / 30mm

Motor does not turn on	A) Li-Po battery depleted	A) Recharge Li-Po battery
	B) Transmitter batteries depleted	B) Replace or recharge batteries
	C) Transmitter not turned on	C) Turn on transmitter
	D) Li-Po battery not plugged in	D) Plug in Li-Po battery
	E) Motor not armed	E) Arm motor
	F) A crash has damaged an internal component	F) Replace
	G) ESC or other damaged	G) Check ESC or contact local distributor
Cub is difficult to control	A) You are flying in too much wind	A) Fly when there is no wind
	B) Li-Po battery depleted	B) Recharge Li-Po battery
	C) Transmitter batteries depleted	C) Replace or recharge batteries
	D) Transmitter antenna not extended completely	D) Extend transmitter antenna completely
	E) Surface control rate is too high	E) Use low rate to fly
The nose always move down when fly, always need to up elevator	A) CG is forward	A) Adjust CG backward refer to instruction
Cub constantly climbs or descends, or turns right or left without control input	A) The aircraft is out of trim adjustment	A) Adjust the transmitter trim tabs
	B) You are flying in too much wind	B) Fly when there is no wind
Elevator is too flexible, up and down is not stable	A) CG is backward	A) Adjust CG forward refer to instruction
Plane will be slant when taxi on the runway	A) Nose gear is not center.	A) Center nose gear
	B) Rudder is not center.	B) Center rudder
Take off is difficult	A) Thrust is not on the high position	A) Thrust is on the high position
	B) Taxi distance is not enough	B) Long taxi distance
	C) Elevator rate is not enough high	C) Use high rate of elevator
Cub will not climb	A) Li-Po battery is depleted	A) Recharge Li-Po battery
	B) Ducted fan is damaged	B) Check and replace ducted fan
	C) Motor is damaged	C) Check and replace motor
	D) ESC overheat protection, power reduction.	D) Landing firstly, check and select a more powerful ESC
Li-Po battery is slightly warm after charging	A) This is normal	A) The Li-Po battery may be slightly warm when fully charged. It should not be hot to the touch.
Motor vibrates excessively	A) Ducted fan is damaged	A) Check and replace ducted fan
	B) Motor is damaged	B) Check and replace motor
	C) Ducted fan is not balance	C) Adjust the ducted fan balance
	D) High speed will happen slightly vibrate	D) Its normal to use
Control surface move the wrong direction	A) Servo direction is reversed	A) Adjust servo reversing function

Accessories list support

EN

Item No.	Product name	Specification	Unit	Qty
E721	90mm EDF power system	90mm ducted fan	set	1
		3748 -1450KV brushless motor	pcs	1
		screw PWA3*12	pcs	6
P0902	90mm ducted fan	12-blade 90mm metal EDF	set	1
M003711	motor	3748 -1450KV brushless motor	pcs	1
FE0101	ESC	100A ESC	pcs	1
MA30172	servo	17g metal gear servo (standard)	pcs	1
MA30172R	servo	17g metal gear servo (reverse)	pcs	1
MA30098	servo	9g metal gear servo (reverse)	pcs	1
FB65035	battery	6S 22.2V 5000mAh 35C	pcs	1
E22	landing gear cabin door sequencer	V2 Version	pcs	1
E01	LED light controller	V3 version 5W LED lamp the highest support	pcs	1
E51	3 axis gyro	3-axis gyro (packed, flight assist system)	pcs	1
FJ305101	fuselage set	/	set	1
FJ305102	main wing set	/	set	1
FJ305103	elevator	/	pcs	1
FJ305104	rudder	/	pcs	1
FJ305105	nose cone	/	pcs	1
FJ305106	cockpit	/	pcs	1
12680	pilot figure	/	pcs	1
FJ305108	electric retracts	/	set	1
FJ3051081	nose landing gear	installed	pcs	1
FJ3051901	LED take off light	LED take off light	pcs	1
		screw PWM3*6	pcs	1
FJ3051902	LED lamp	5W LED lamp	pcs	2
FJ3051903	LED light cover	LED light cover	pcs	1
		LED light base	pcs	1
		screw PWM3*6	pcs	1
FJ3051082	nose landing gear steering arm	/	pcs	1
FJ3051083	nose landing gear metal wire	nose landing gear metal wire	pcs	1
		E buckle 2.0	pcs	1
		screw PT2.6*6	pcs	1
		jimi screw M4*4	pcs	2
FJ3051084	nose landing gear damping set	nose landing gear damping set(installed)	set	1
		screw PM2*3	pcs	1
		screw PM2*4	pcs	1
		jimi screw M4*4	pcs	2
		jimi screw M3*5	pcs	1
FJ3051085	wheel shaft of nose landing gear	wheel shaft	pcs	1
		jimi screw M3*3	pcs	1
		jimi screw M3*5	pcs	1
FJ3051086L	rear landing gear	installed (Left)	pcs	1
FJ3051086R	rear landing gear	installed (Right)	pcs	1
FJ3051087	rear landing gear metal wire	rear landing gear metal wire	pcs	1
		jimi screw M3*5	pcs	2
		jimi screw M4*4	pcs	2
FJ3051088	rear landing gear damping set	rear landing gear damping set	pcs	1
		jimi screw M4*4	pcs	3

Item No.	Product name	Specification	Unit	Qty
FJ3051089	rear landing gear wheel shaft	rear landing gear wheel shaft	pcs	1
		jimi screw M4*4	pcs	1
FJ3051091	landing gear cabin cover	nose landing gear cabin cover	set	1
		rear landing gear cabin cover	set	1
		screw PM4*5	pcs	2
FJ3051092	Stinger90 plastic part	/	set	1
N204	pushrod plastic buckle	/	pcs	6
N102	control surface horn	control surface horn	pcs	7
		metal ball	pcs	7
FJ305111	pushrod	main wing control pushrod (include metal ball)	pcs	2
		flap control pushrod (include metal ball)	pcs	2
		elevator control pushrod (include metal ball)	pcs	2
		rudder control pushrod (include metal ball)	pcs	1
		nose cabin servo control pushrod (include metal ball)	pcs	2
		nose steering control pushrod (include metal ball)	pcs	1
N205	metal ball	metal ball	pcs	8
N206	plastic ball head buckle	plastic ball head buckle	pcs	8
N303	flap unidirectional leaf	/	pcs	8
N901	special servo arm	arm of nose steering	pcs	2
FJ305112	Stinger 90 screw bag	screw FM2*10	pcs	7
		screw PM3*40	pcs	4
		screw M3*14	pcs	1
		screw PM4*5	pcs	2
		screw PM3*6	pcs	1
		screw PM2*3	pcs	1
		screw PM2*4	pcs	3
		screw PWM3*8	pcs	3
		screw PWA3*12	pcs	10
		screw PWA3*8	pcs	2
		screw PWA2*8	pcs	10
		nut M2	pcs	7
		screw PWA1.7*5	pcs	14
		screw KA3*12	pcs	8
		screw PA3*25	pcs	10
		screw PT2.6*6	pcs	1
		screw M3*6	pcs	4
screw M3*10	pcs	1		
screw M4*4	pcs	6		
screw M3*5	pcs	5		
screw M3*3	pcs	3		

非常感谢您购买我们的Stinger 90这款模型飞机，Stinger 90是在我们Stinger 64的基础上经过外形放大，修改后，重新推出的一款90mm动力涵道的运动机。

这款飞机采用了许多非常优秀的设计思想：无缝襟翼和无缝副翼的设计，使得飞机的表面外观，更加漂亮整洁；17g金属舵机，新的舵面摇臂和钢丝夹头，使飞机的舵面操控更加可靠和精准，也可以承受更大的负载；新的多叶涵道风扇和涵道电机的优秀搭配，可以产生更大的推力及更优秀的声音效果；新的LED滑行灯，更加给人一种全新的视觉享受！

⚠ 注意：模型产品是具有一定危险性的产品，请禁止14岁以下的儿童玩耍，14岁以上的儿童，请在有飞行经验的成人指导下使用，无飞行经验的购买者，应当在具有一定电动涵道飞机飞行经验的成人指导下使用！组装模型前，请仔细阅读说明书，按照说明书的要求进行安装、进行调试和飞行时，请根据说明书指示的参数进行调整。

重要提示

1. 模型飞机不是玩具，操作者需要具备一定的经验；没有经验的初学者，必须在有丰富经验的专业人士指引下，逐步学习！
2. 在组装之前，必须认真阅读产品说明书，严格按照说明书指示操作。
3. 飞翼模型及其销售商，对于违反说明书的要求操作而造成的损失、将不负任何法律责任！
4. 模型飞机的使用年龄必须是14岁以上的儿童或者成人。
5. 此模型产品使用EPO材料制成，表面喷涂油漆，不可随意使用化学制剂擦拭，否则会损坏模型产品。
6. 不能在公共场合、高压线密集区、高速公路附近、机场附近或者其它法律法规明确禁止飞行的场合飞行。
7. 不能在雷雨、大风、大雪或者其它恶劣气象环境下飞行。
8. 模型飞机的电池产品，不可以随意乱扔，乱放。存放时，必须保证周边2M范围内，无易燃、易爆物体。
9. 损坏或者报废处理的模型飞机电池，应妥善回收处理，不准随意抛弃，避免自燃而引发火灾。
10. 在飞场飞行时，应做到妥善处理飞行后所产生的垃圾，不可随意抛弃、焚毁模型及其配件。
11. 在任何情况下，都必须保证油门杆处于起始位、发射机处于打开状态时，才能连接模型飞机内部的动力电池。
12. 无论是模型飞机是在正常飞行过程中，或者是在缓慢降落过程中，都不要尝试用手去回收模型。必须等模型降落停稳以下，再进行回收！

组装资料索引

产品基本参数	17
产品包装清单	17
机翼组装说明	18
前起落架组装	21
后起落架组装	22
舵机安装说明	22
电池安装说明	24
重心说明	24
动力系统组装及马达参数	25
舵面测试	27
大、小舵参数设定	28
飞行故障检修指导	29
可支持配件列表	30

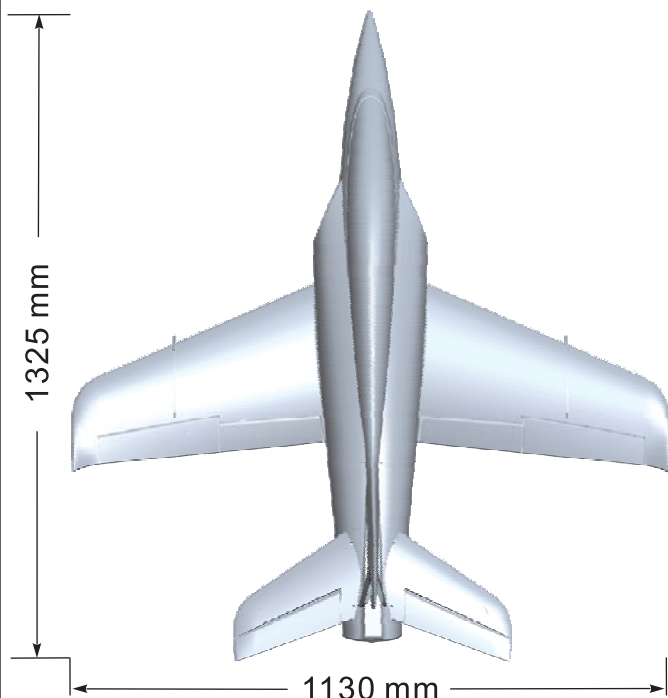

1325 mm

1130 mm

⚠ 注意：此处各项参数，均使用本公司配件测试得出，如果使用副厂配件，会有所差异。使用副厂配件时所产生的问题，我们将无法给予技术支持！

- 电机
3748-1450KV (涵道动力版本使用)
- 电调
100A 无刷电调 (UBEC8A)
- 舵机
17g 全金属舵机 (7pcs)
9g 全金属舵机 (2pcs)
- 电池
6S 22.2V 5000mAh 35C
1S 3.7V 450mAh 25C (LED滑行灯电源)
- 涵道风扇
90mm 12叶涵道
- 起飞重量
2800g (称重时，使用工厂标准配置)
- 推力
3200g
- 飞行时间
全油门飞行时间：3分钟
最大飞行时间：5分钟

起落架	副翼	襟翼	升降舵	方向舵	油门控制
金属电动收放起落架	有	有	有	有	有

产品包装清单



打开产品包装，核对包装清单。(不同配置的版本，包含内容不同！)

序号	配件名称	ARF	PNP	KIT
1	机身套件 (内置连接线)	有	有	有
2	主翼套件	有	有	有
3	尾翼套件	有	有	有
4	机头罩 (2个)	有	有	有

序号	配件名称	ARF	PNP	KIT
5	电池	有	无	无
6	Y线	有	有	有
7	碳纤维管	有	有	有
8	螺丝刀及螺丝	有	有	有

首先，我们从包装盒内取出机身、主翼及胶水，准备安装；

- A- 机身套件
- B- 左、右主翼
- C- 碳纤维
- D- 螺丝 PWM3*6 2pcs
- E- 螺丝 PM3*40 4pcs
- F- “Y”线

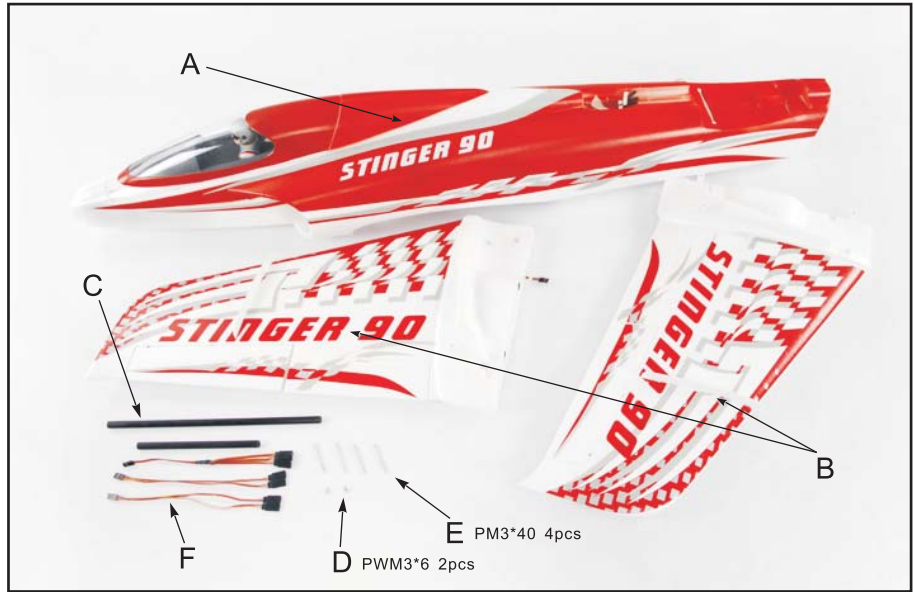

1. 把碳纤维管“C”插入机身；
2. 然后将左、右主翼对插在一起；
3. 用2颗螺丝“D”锁紧；

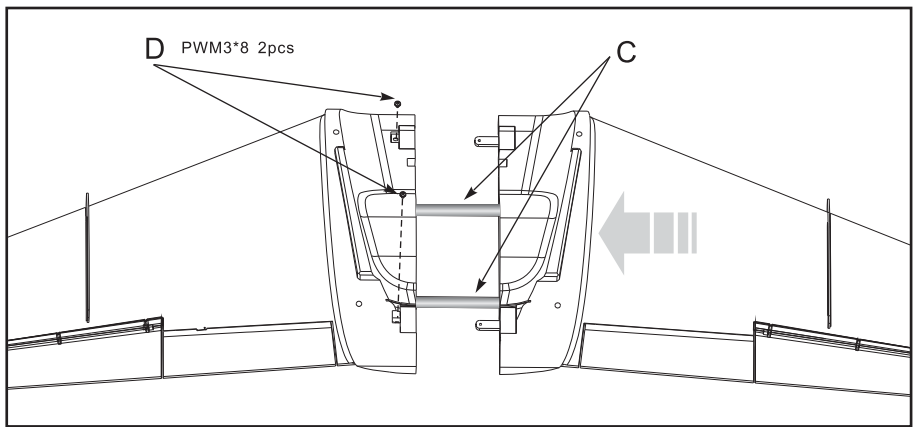

4. 分别用二根Y线“F”连接副翼舵机线和襟翼舵机线；
5. 如右图所示：将Y线“F”沿箭头方向，从机身区域“G”穿入到座舱内；
6. 最后把主翼安装到机身上，并用4颗螺丝“E”锁紧；

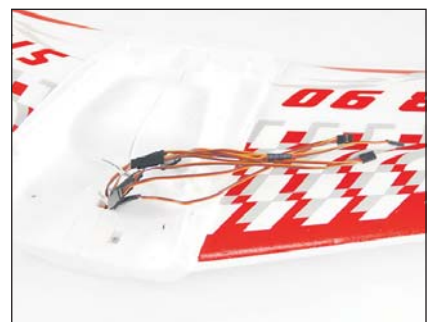
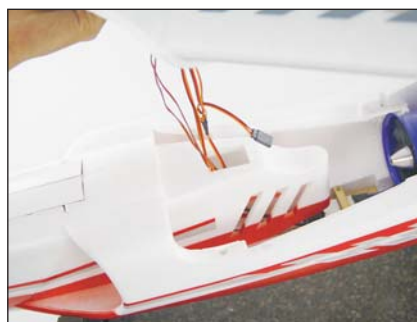
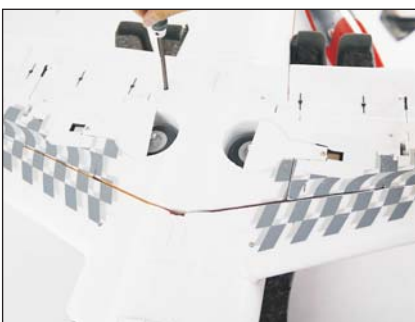
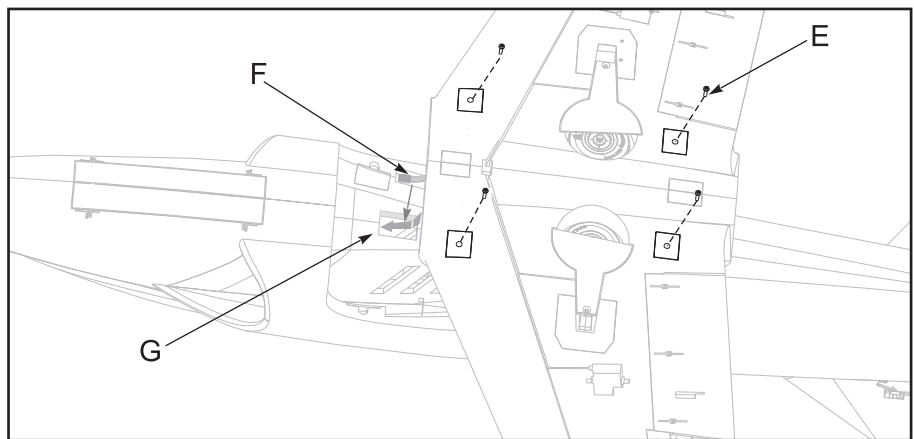

接下来，我们取出平尾，继续安装；

A - 组装好主翼的机身

B - 平尾

C - 螺丝 PA3*25 4pcs

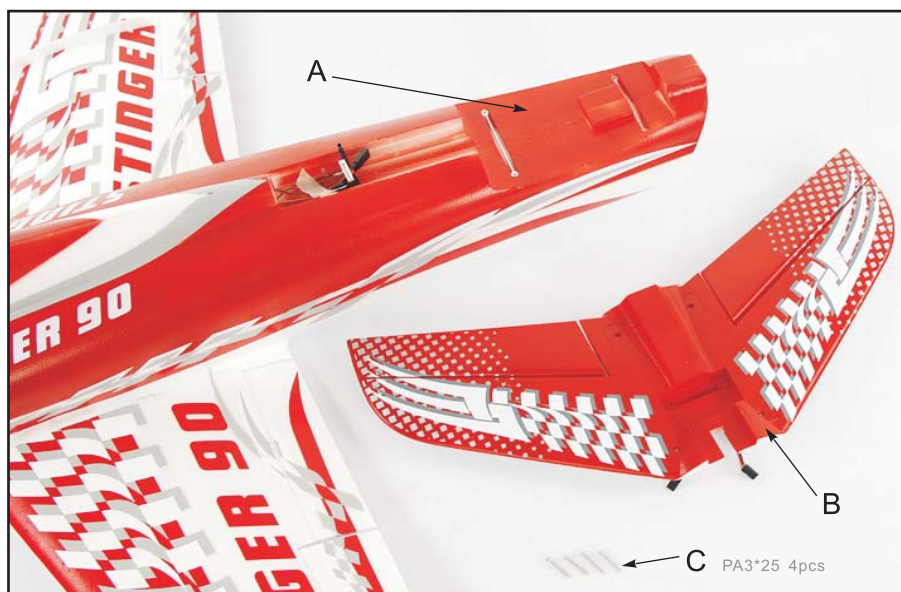

1. 把平尾舵机线“D”分别与机身内置Y线“E”连接起来；

2. 然后将平尾安装到机身上，安装平尾的过程中，我们需要把过长的舵机线塞入机身线槽“F”内；

3. 用螺丝“C”固定平尾；

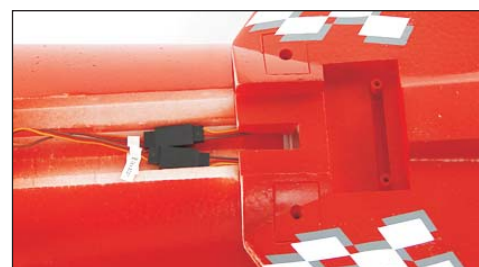
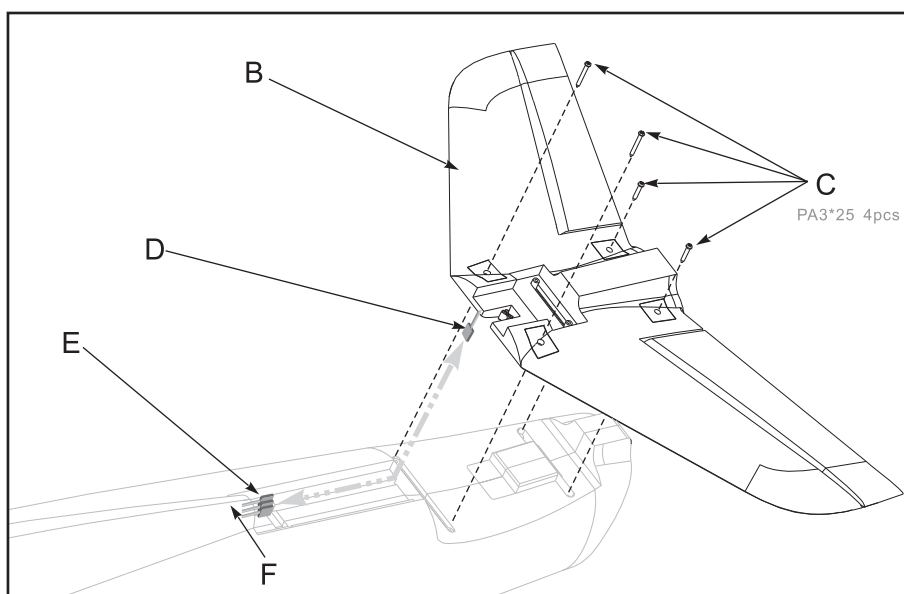

接下来，我们取出垂尾，继续安装；

- A - 机身
- B - 垂尾
- C - 螺丝 PA3*25 4pcs

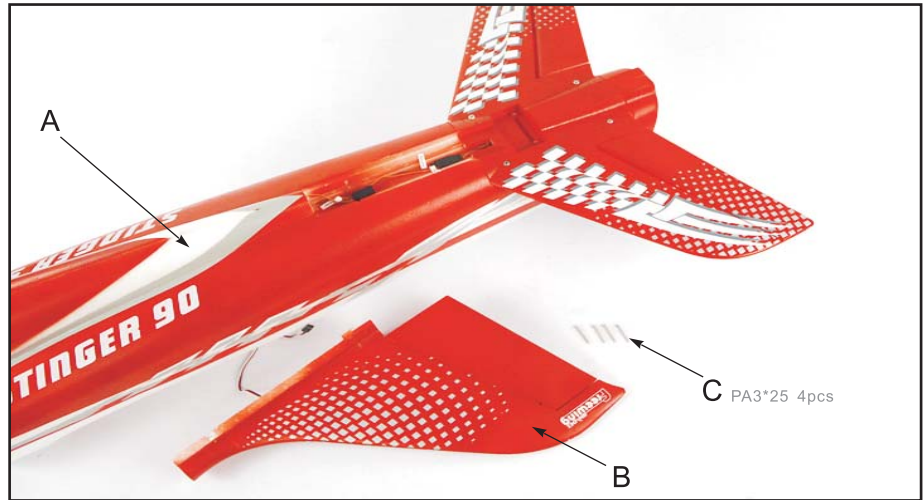

1. 把垂尾舵机线“F”与机身内置延长线“G”连接起来；
2. 然后将垂尾安装到机身上，安装垂尾的过程中，我们需要把过长的舵机线塞入机身线槽“H”内；
3. 把垂尾V型塑料件“C”安装到垂尾上；
4. 分别用螺丝“D”和“E”固定平尾；

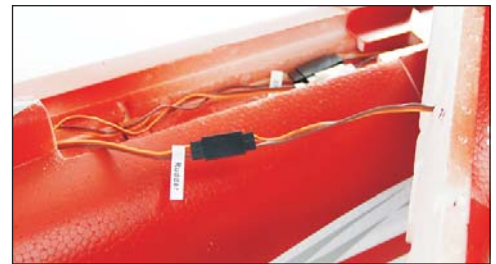
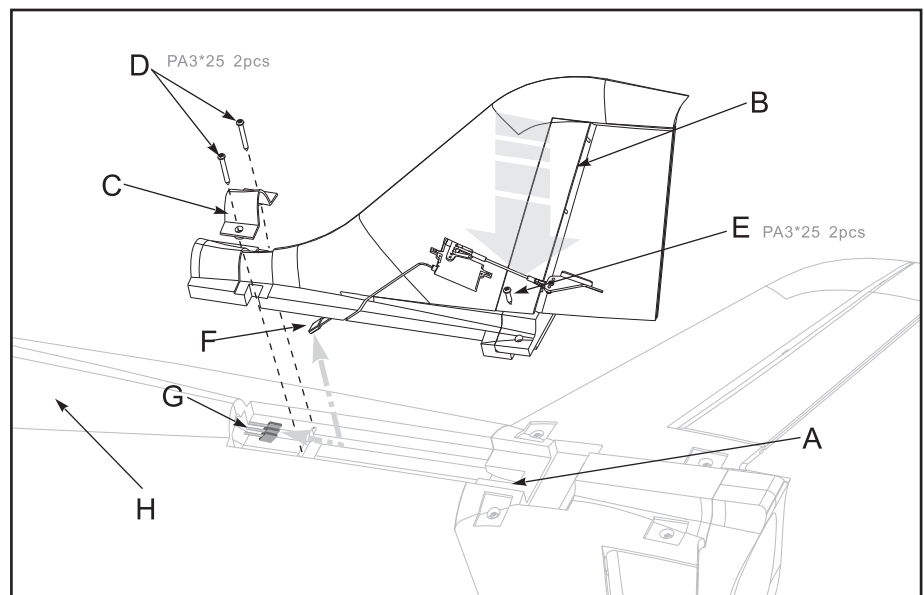

机头罩安装

在包装盒内有2个机头罩，其中1个为工厂赠品，做为未来更换使用。

- A - 机头罩
- B - 螺丝 PWA3*8 2pcs

将机头罩“A”插入机身机头部位，然后使用2颗螺丝“B”锁紧固定。

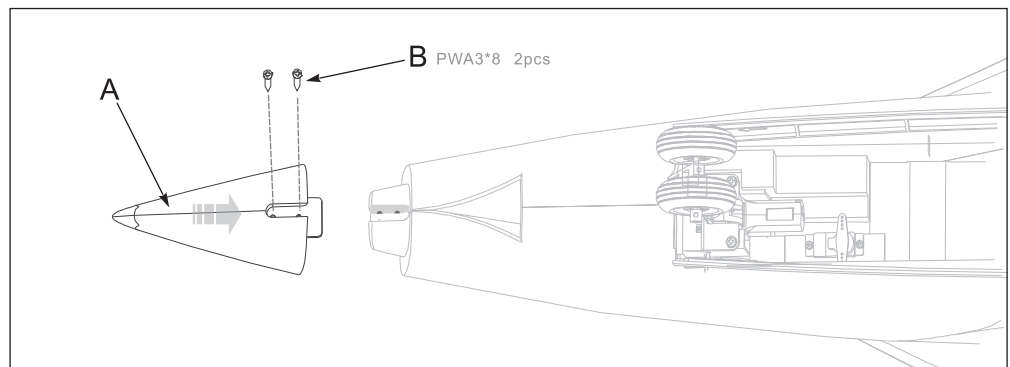

一般情况下，起落架在出厂前，都是已经组装完成的。在这里，我们还是需要详细介绍起落架的组装及各部件的名称，玩家在自行改装、维修、更换配件时可以做为参考依据！

前起落架零件列表：

- | | |
|-------------|-------------|
| A- 电动起落架基座 | R- 8字型减震转轴 |
| B- 电动起落架旋转臂 | S- 梢钉 |
| C- E型扣 | T- E型扣 |
| D- 前起落架钢丝 | U- 倾斜支撑杆 |
| E- 前起落架转向钢丝 | V- 机轮 |
| F- 前起落架转向摇臂 | W- 轮轴 |
| G- 螺丝 | X- 垫圈 |
| H- 前起落架主撑杆 | Y- 机米螺丝 |
| I- 机米螺丝 | Z- 金属套 |
| J- 卡线槽 | AB- 机米螺丝 |
| K- 滑行灯 | |
| L- 螺丝 | |
| M- U型减震摇臂 | AC- 前起落架组件 |
| N- 螺丝 | AD- 前起落架安装座 |
| O- 弹簧 | AE- 螺丝 |
| P- 减震活动杆 | |
| Q- 螺丝 | |

1. 将电动起落架基座“A”拆开，取出电动起落架旋转臂“B”；
2. 前起落架钢丝“D”插入电动起落架旋转臂“B”后，用E型扣“C”卡住钢丝“D”下端，防止钢丝脱落；
3. 把前起落架转向摇臂“F”套入前起落架钢丝“D”内，然后用1颗螺丝“G”，将其固定在钢丝“D”上，最后将前起落架转向钢丝“E”直接拧入到转向摇臂“F”上；
4. 将前起落架主撑杆“H”套在前起落架钢丝“D”上，使用2颗螺丝从二侧锁入固定；将卡线槽“J”用502胶水粘到前起落架主撑杆“H”上，然后用螺丝“L”把滑行灯“K”固定到前起落架主撑杆“H”上，最后，将灯线卡入卡线槽“J”内。
5. 将U型减震摇臂“M”套入前起落架主撑杆“H”，并用1颗螺丝“N”固定；
6. 把弹“O”放入到前起落架主撑杆“H”内，再放入减震活动杆“P”，用力压住减震活动杆“P”的同时，将螺丝“Q”锁到前起落架主撑杆“H”上。
7. 将8字型减震转轴“R”套入到U型减震摇臂“M”内，然后插入1颗梢钉“S”，并用E型扣“E”固定；
8. 把倾斜支撑杆“U”一端套入8字型减震转轴“R”上，然后插入1颗梢钉“S”，并用E型扣“E”固定，另一端套入减震活动杆“P”顶端，同样地插入1颗梢钉“S”，并用E型扣“E”固定；

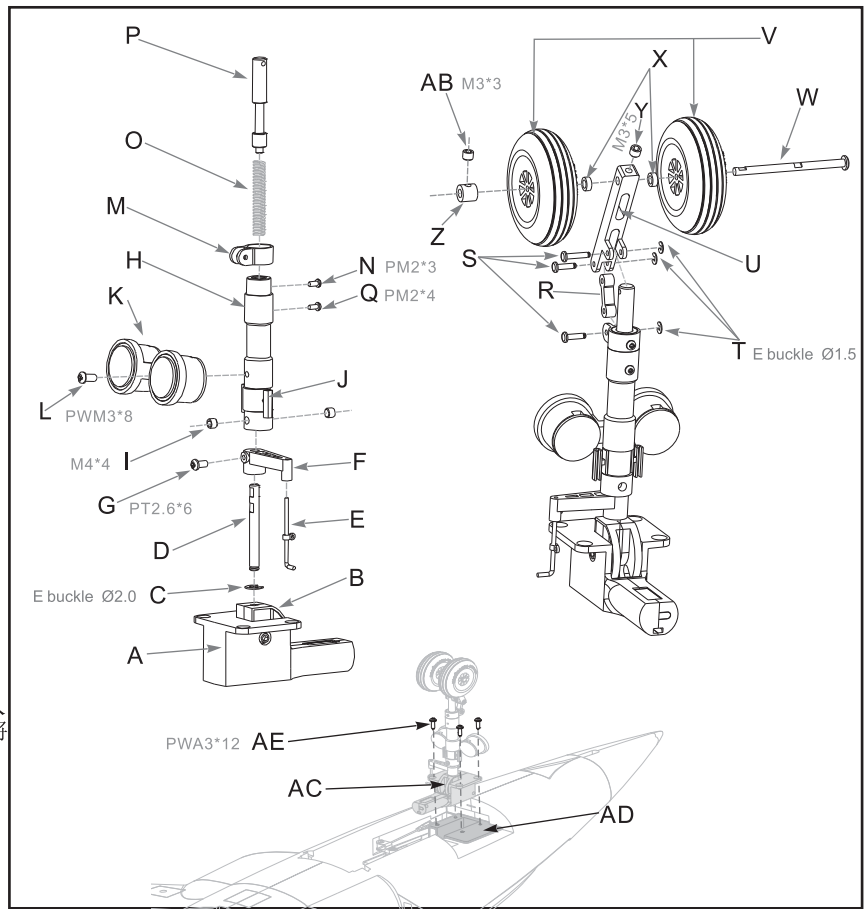

9. 把机轮“V”套入到轮轴“W”上，再将垫圈“X”套入到轮轴“W”。然后将轮轴“W”连同机轮、垫圈一起穿入到倾斜支撑杆“U”内，并用1颗螺丝“Y”固定；
10. 把另一个垫圈“X”套入到轮轴“W”，再套入另外一只机轮“V”，最后套入金属套“Z”，同机米螺丝“AB”固定；

11. 把组装完成的起落架套件“AC”装入前起落架安装座“AD”内，最后用4颗螺丝锁紧固定；

⚠ 注意：在整个起落架组装过程中，所有带扁口的零件，在用螺丝固定时，扁口面必须面向螺丝孔，只有这样，螺丝的固定才是有效的，零件才不会转动和脱落；

⚠ 注意：说明书后面附有产品名称及工厂内物料编码，如果需要购买配件，请参考并向经销商咨询！

前轮转向舵机安装

配件名称

- | |
|-------------|
| A- 9g金属舵机 |
| B- 螺丝 |
| C- 螺丝 |
| D- 螺丝 |
| E- U型舵机摇臂 |
| F- 舵机控制钢丝 |
| G- 起落架转向控制环 |

1. 将舵机“A”安装到木片上，用螺丝“B”固定舵机，然后将U型舵机摇臂“E”安装到舵机上，同时用螺丝“C”固定摇臂；
2. 将起落架舵机控制钢丝“F”一端夹头扣入起落架转向控制环“G”内，另一端穿入U型舵机摇臂“E”中，调整插入去深度直至前轮居中；
3. 用螺丝“D”固定舵机控制钢丝“F”；

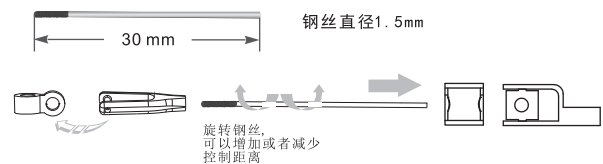

前轮转向舵机安装座尺寸参数

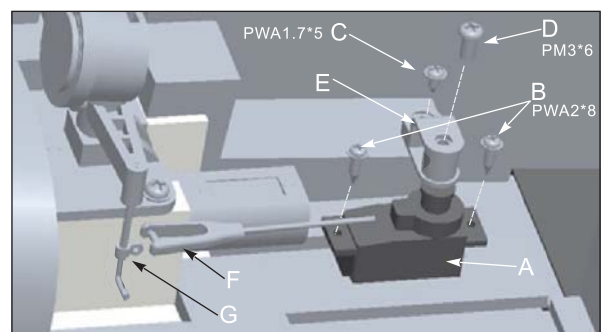
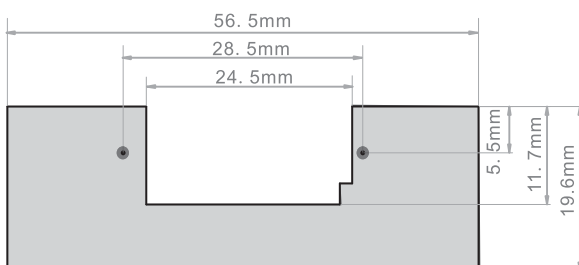

前起落架零件列表:

- A- 电动起落架旋转臂
- B- 机米螺丝
- C- 后起落架钢丝
- D- 后起落架主撑杆
- E- 机米螺丝
- F- 弹簧
- G- 后起落架减震活动杆
- H- 梢钉
- I- 后起落架舱门盖
- J- 螺丝
- K- 后机轮轴
- L- 机轮
- M- 垫圈
- N- 机米螺丝
- O- 后起落架组件
- P- 后起落架安装座
- Q- 螺丝
- R- U型吸塑片

1. 将后起落架钢丝“C”插入到电动起落架旋转臂中，用2颗机米螺丝“B”固定；
2. 把后起落架架主撑杆“D”套入到后起落架钢丝“C”中，并用螺丝“E”锁紧；
3. 将弹簧“F”套进后起落架架主撑杆“D”中，再将后起落架减震活动杆“G”穿入到后起落架架主撑杆“D”中并用力向下压住，同时将梢钉“H”压入到后起落架减震活动杆“G”圆孔内；
4. 把机轮“L”套入后机轮轴“K”，再套入垫圈“M”，最后将后机轮轴穿入后起落架减震活动杆“G”圆孔内，用机米螺丝“N”锁紧；
5. 把后起落架舱门盖“I”卡到后起落架主撑杆“D”上，并用螺丝“J”固定；

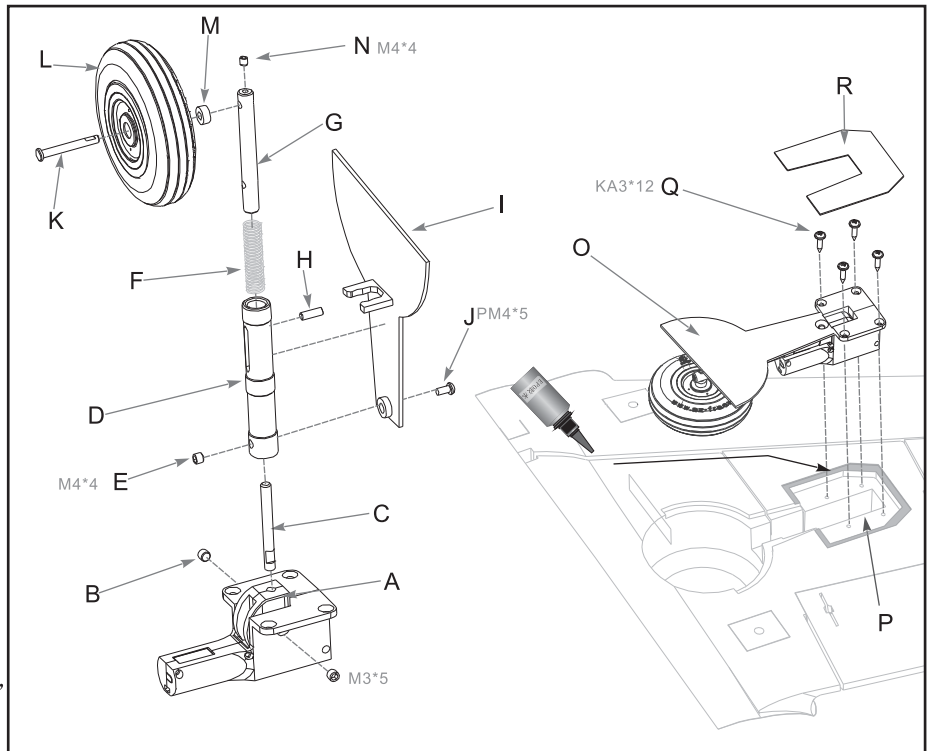

6. 把组装好的后起落架组件“O”安装到后起落架安装座“P”内，然后用4颗螺丝“Q”固定；
7. 在主翼下表面（上图深灰色阴影区域）相关区域，涂摸胶水，将U型吸塑片粘贴到主翼上；

注意：在整个起落架组装过程中，所有带扁口的零件，在用螺丝固定时，扁口面必须面向螺丝孔，只有这样，螺丝的固定才是有效的，零件才不会转动和脱落；

注意：说明书后面附有产品名称及工厂内物料编码，如果需要购买配件，请参考并向经销商咨询！

主翼舵机安装

1. 在右图所示阴影区域，涂抹胶水，然后将17g舵机盒“B”和舵面摇臂“A”粘贴到主翼上；
2. 把17g舵机“C”压入舵机盒内，同时将舵机线“G”压入主翼线槽“H”内；
3. 把舵机盖“D”盖到舵机盒“B”上，并用2颗螺丝“E”锁紧固定；
4. 用舵机控制钢丝“F”将舵机摇臂与舵面摇臂连接起来；
5. 将舵面调整到居中状态。

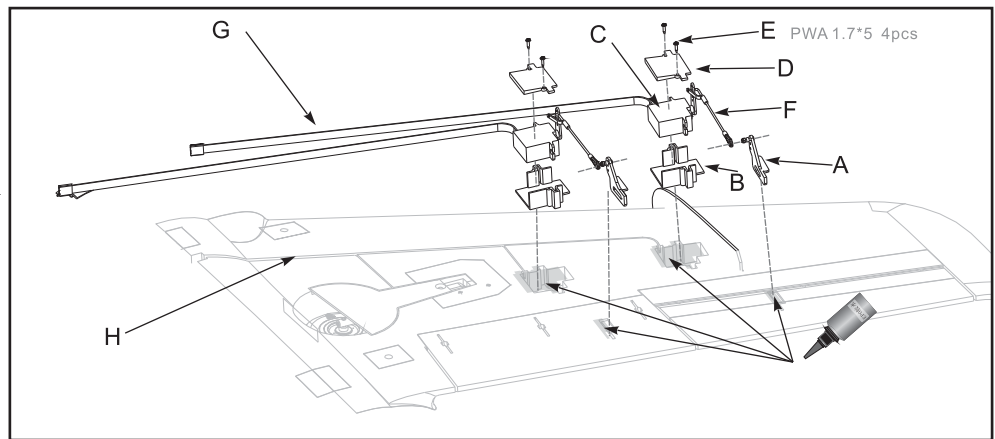

注意：模型所有舵机安装位置已经安装好舵机盒，使玩家在拆卸舵机时，不会损伤机身表面。如果需要更换舵机，请购买原厂舵机或者参考下列图纸，选择尺寸相符的舵机！

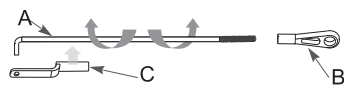

1. 将钢丝“A”有螺纹一端拧到球头扣“B”内，做成一根舵面控制钢丝。我们可以通过向左、向右扭转钢丝，来增加或者减少舵面控制钢丝的总长；
2. 钢丝折角一端，穿入舵机摇臂内，然后将塑料扣“C”下半端扣到钢丝“A”上，上半端圆孔扣进钢丝内，达到固定的效果！

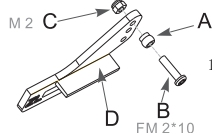

1. 将球头“A”套入螺丝“B”内，然后再把螺丝“B”穿入舵面摇臂“D”圆孔内，最后用螺母“C”拧紧；

副翼控制钢丝尺寸

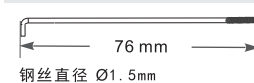

副翼控制钢丝尺寸



副翼舵机钢丝安装孔位

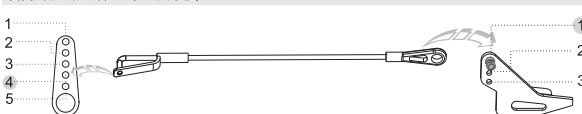

襟翼舵机钢丝安装孔位



1. 在右图所示阴影区域，涂抹胶水，然后将17g舵机盒“A”和舵面摇臂“B”粘贴到主翼上；
2. 把17g舵机“C”压入舵机盒内，同时将舵机线“D”压入主翼线槽“G”内；
3. 把舵机盖“E”盖到舵机盒“B”上，并用2颗螺丝“F”锁紧固定；
4. 用舵机控制钢丝“H”将舵机摇臂与舵面摇臂连接起来；
5. 将舵面调整到居中状态；
6. 使用同样的步骤安装另一侧的平尾舵机及垂尾舵机。

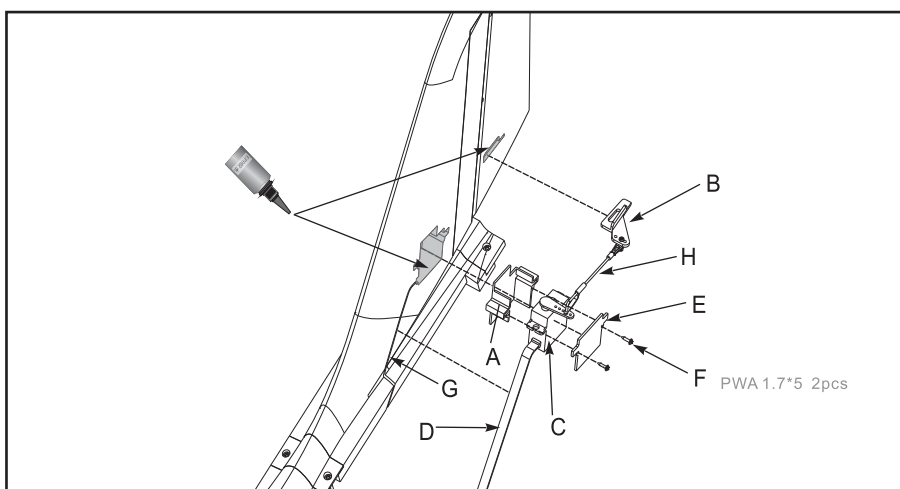
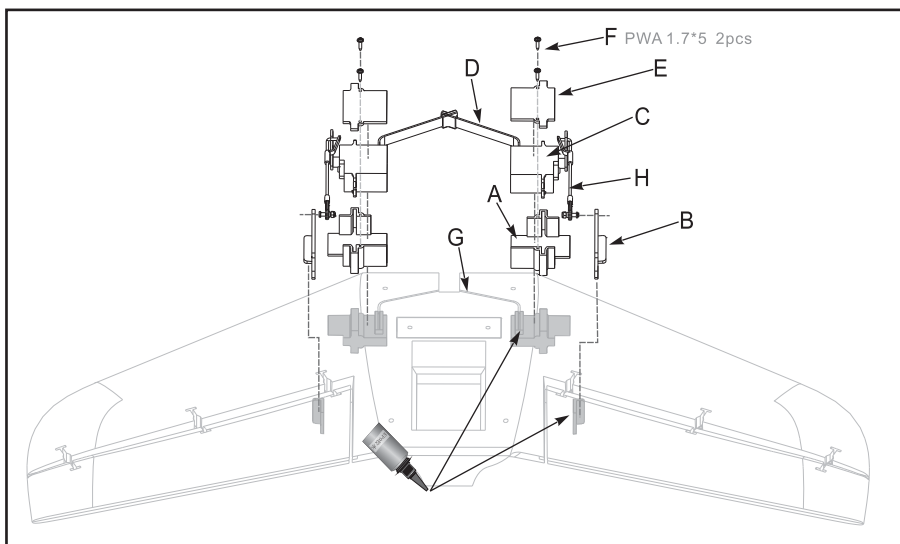

注意：模型所有舵机安装位置已经安装好舵机盒，使玩家在拆卸舵机时，不会损伤机身表面。如果需要更换舵机，请购买原厂舵机或者参考下列图纸，选择尺寸相符的舵机！

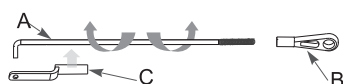

1. 将钢丝“A”有螺纹一端拧到球头扣“B”内，做成一根舵面控制钢丝。我们可以通过向左、向右扭转钢丝，来增加或者减少舵面控制钢丝的总长；
2. 钢丝折角一端，穿入舵机摇臂内，然后将塑料扣“C”下半端扣到钢丝“A”上，上半端圆孔扣进钢丝内，达到固定的效果！

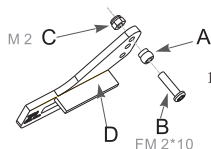
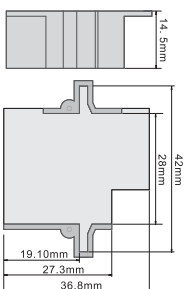

1. 将球头“A”套入螺丝“B”内，然后再把螺丝“B”穿入舵面摇臂“D”圆孔内，最后用螺母“C”拧紧；

平尾控制钢丝尺寸

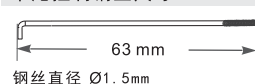

垂尾控制钢丝尺寸

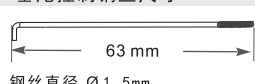

平尾舵机钢丝安装孔位

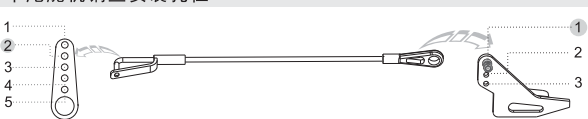

垂尾舵机钢丝安装孔位



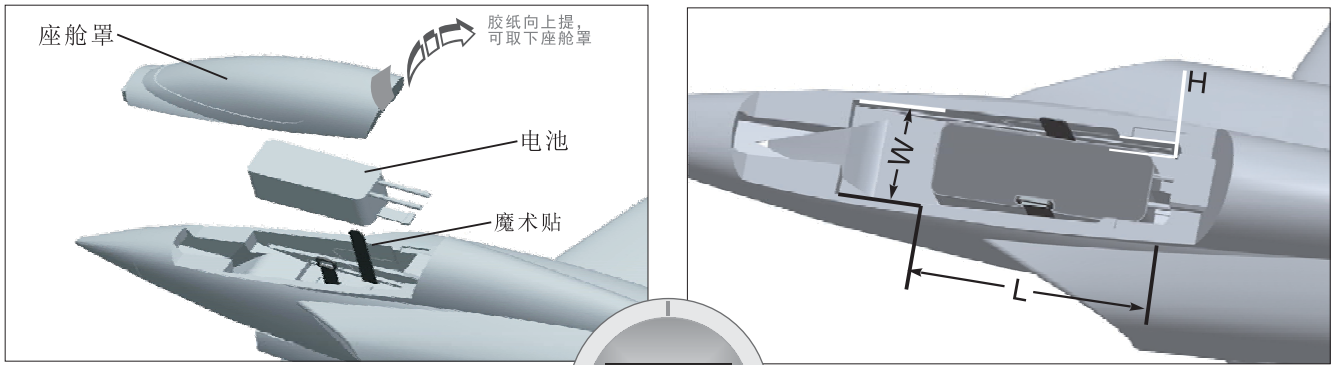

向上拉粘在座舱上的胶纸，取下座舱盖，然后用魔术贴捆绑电池。
 将电池与接收机连接前，首先请打开发射机电源，确认油门杆处于低位。
 电池与电调的连接头，采用的XT150连接头最大通过电流值为120A，请不要过载使用！

我们出厂时配备的电池为：
 6S 22.2V 5000mAh 35C
 您可以参考电池舱尺寸，选择其它规格的电池！
L=180mm; W=60mm; H=48mm
 我们建议使用的电池容量和放电倍率如下：
6S 22.2V 3200mAh ~ 6S 22.2V 5500mAh
 放电倍率 **> 35C**

不同重量的电池,会影响重心! 请注意飞机的重心在说明书指示的正确范围内!

重心示意图

正确的重心，直接关系到飞行的成功与否，请参考下面的重心标示图，来调整飞机的重心。

- 您可以将电池向前，或者向后移动，来调整飞机的重心；
- 如果通过电调的移动无法调整到正确的重心位置，您还可以适当的使用一些其它材料来配重，使飞机的重心处于正确的位置！

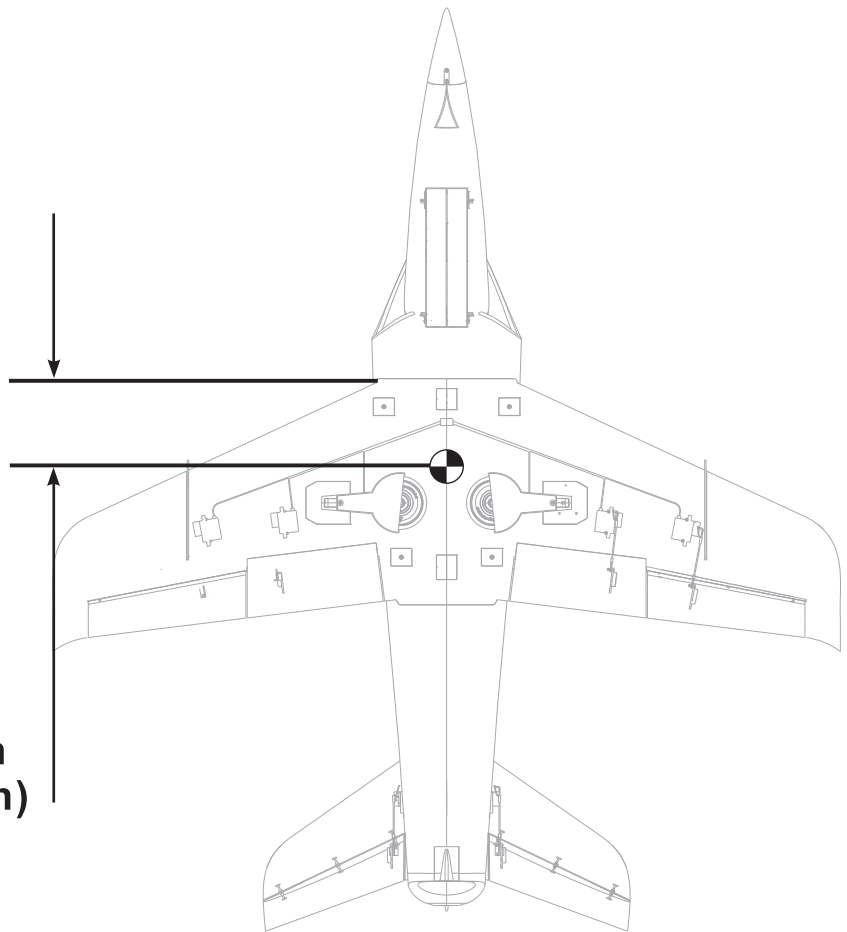

110~120mm
(4.33~4.73 in)

1. 将电机“D”装入涵道框“C”内；
2. 用4颗杯头螺丝“B”固定马达；
3. 把涵道风扇“E”套入到电机轴上；
(在此过程中，请注意风扇叶内嵌五金件的扁口与马达轴的扁口部位对齐装入)
4. 用整流罩“F”盖住风扇叶，最后用杯头螺丝“G”固定整流罩“F”。
5. 最后把尾部导流罩“A”安装到涵道框“C”底部，并用2颗机米螺丝“H”固定。

6. 将马达与机身内电调连接起来；
7. 把组装好的涵道“I”放置到机身“K”内；
8. 最后使用6颗螺丝“J”将涵道“I”锁到固定木片上；

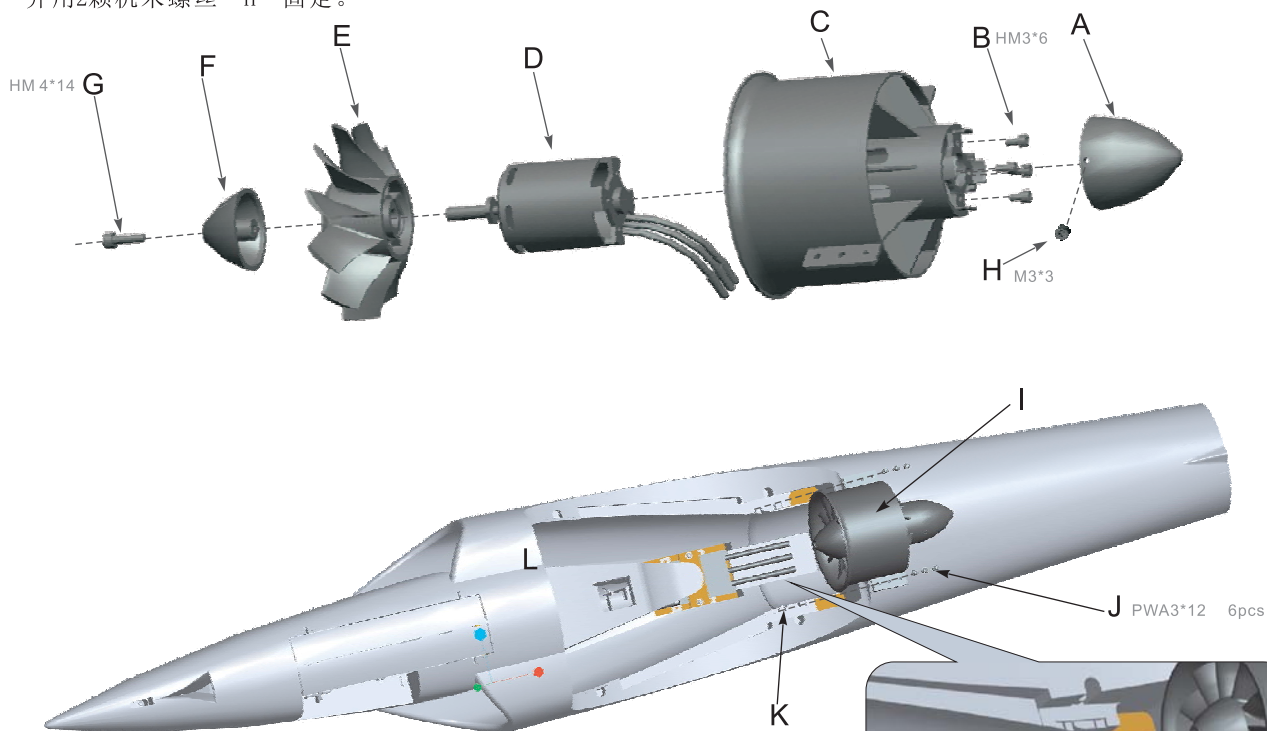

注意：当电调与电池连接后，禁止用手触摸电调和涵道，防止意外伤害！测试涵道时，请使用安全的测试架进行测试，禁止用手抓住涵道的进行行为！

注意：测试涵道时，如果发现电机反转，我们可以调换“1”号线与“3”号线的连接，改变电机的转向！

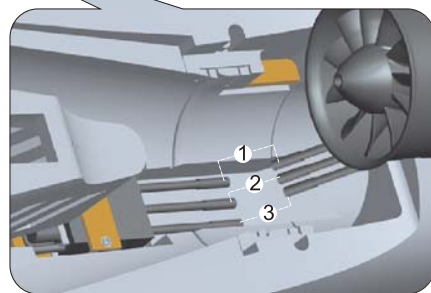

电机参数

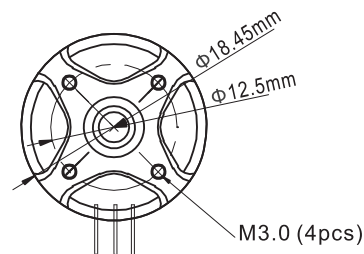
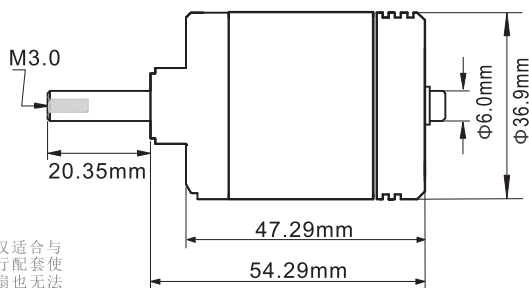
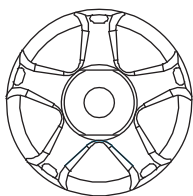

注意：此电机为专用产品，仅适合与飞翼公司型号为P0902涵道风扇进行配套使用，同时，型号为P0902的涵道风扇也无法安装其它电机！

Item No.	KV Value	Voltage (V)	Current (A)	Pull (g)	Motor Resistance	Weight (g)	No Load Current	Propeller	ESC
MO03712	1450RPM/V	22.2	80	3600	0.02 Ω	195	2.7A/10V	90mm Ducted Fan	≥ 95A

1. 将电机“A”装入涵道框“B”内；
2. 用4颗杯头螺丝“C”固定马达；
3. 将桨夹“E”套入马达轴，并用四颗机米螺丝“D”固定桨夹“E”；
4. 把涵道风扇“F”套入到桨夹“E”上；
(在此过程中，请注意风扇叶内嵌五金件的扁口与马达轴的扁口部位对齐装入)
5. 用整流罩“G”罩在风扇“F”顶端，最后用杯头螺丝“H”固定整流罩“G”。
6. 最后把尾部整流罩“A”安装到涵道框“C”底部，并用2颗机米螺丝“H”固定。
7. 将马达与机身内电调连接起来；
8. 把组装好的涵道“I”放入机身；
9. 把涵道固定环“J”卡入涵道框外表面凹槽内，最后用6颗螺丝“K”将固定环“J”固定到木片“L”上；

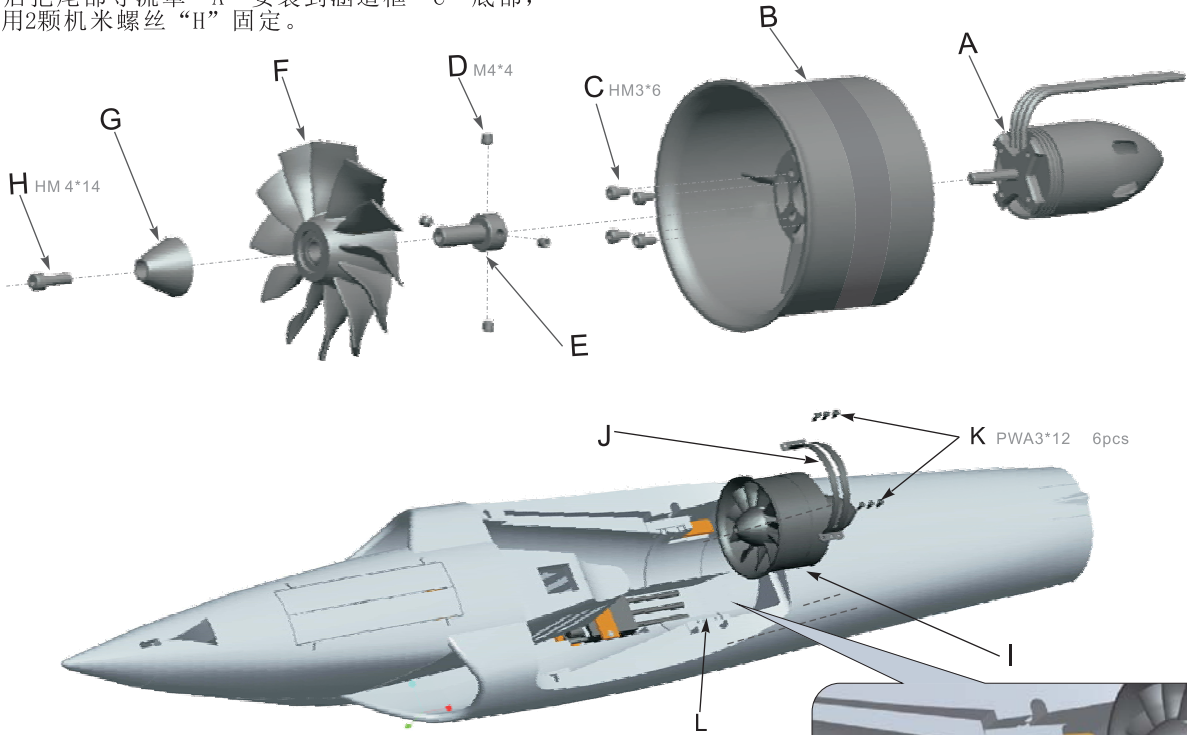

⚠注意：当电调与电池连接后，禁止用手触摸电调和涵道，防止意外伤害！测试涵道时，请使用安全的测试架进行测试，禁止用手抓住涵道的进行行为！

⚠注意：测试涵道时，如果发现电机反转，我们可以调换“1”号线与“3”号线的连接，改变电机的转向！

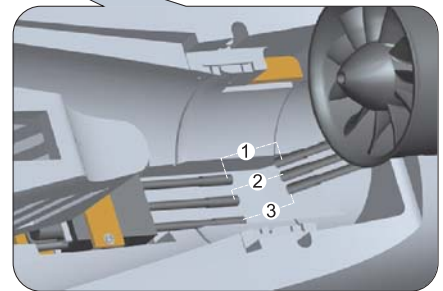

电机参数

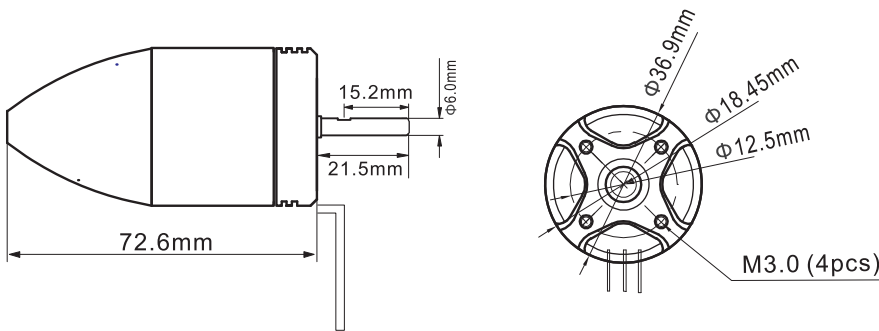

⚠注意：如果需要购买副厂马达使用，请参考左图所示的尺寸图，来选择马达，确保您所购买的马达能够顺利安装。

Item No.	KV Value	Volate (V)	Current (A)	Pull (g)	Motor Resistance	Weight (g)	No Load Current	Propeller	ESC
MO03711	1450RPM/V	22.2	83	3400	0.02 Ω	195	2.7A/10V	90mm Ducted Fan	≥ 95A

当您按前面的步骤组装好飞机后，在飞行前，我们需要用一块充电的电池，连接到电调。用遥控器测试每个舵面的工作情况，检查是否正常！

副翼

副翼摇杆
向左运动

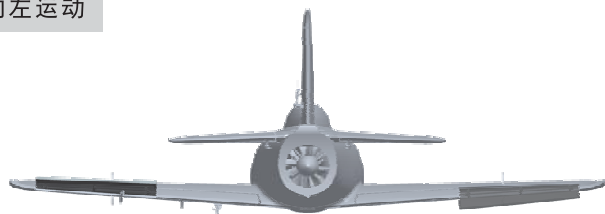

副翼摇杆
向右运动

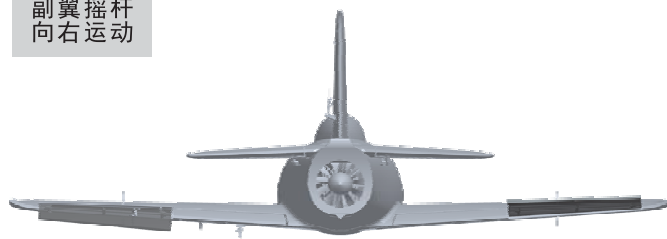

升降舵

升降摇杆
向下运动

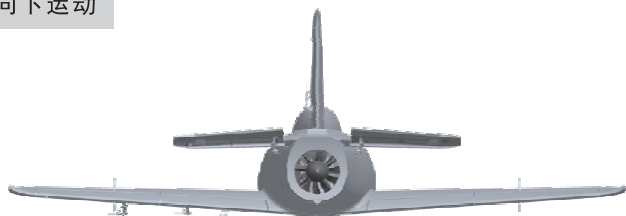

副翼摇杆
向上运动



方向舵

方向摇杆
向左运动

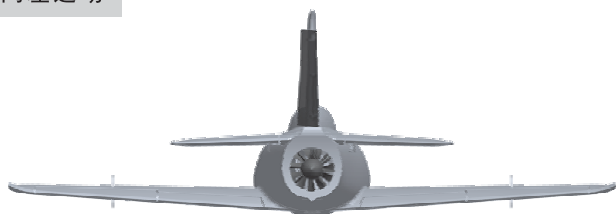

方向摇杆
向右运动



襟翼

襟翼放下



根据我们的测试经验，我们认为，按以下参数来设置副翼和升降舵的大、小舵，将有助于飞行。在小舵角的情况下，飞机的可操控性能会好一些，适合初次飞行或者不太熟练的玩家飞行。而大舵角的设置，可以提高动作灵敏度，使用经验丰富的玩家。您可以根据自身的情况，来选择其中一种舵量进行飞行！

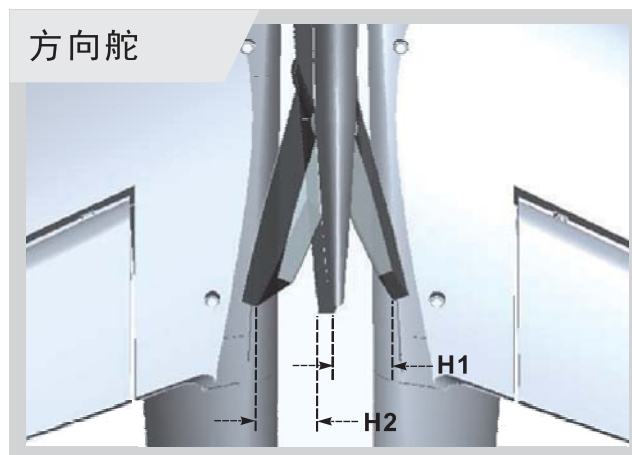
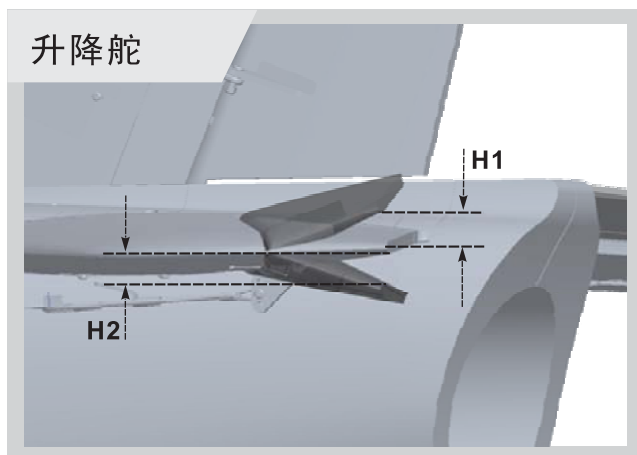
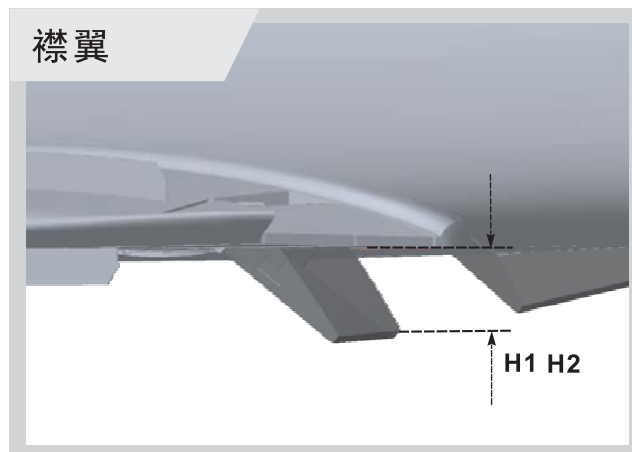
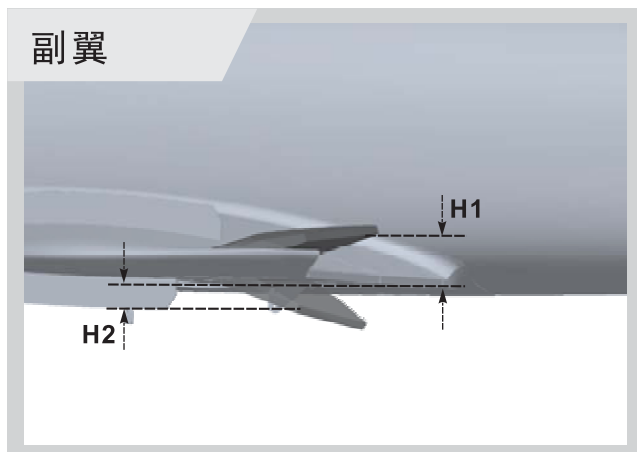

	副翼	襟翼	升降舵	方向舵
小舵角	H1/H2 14mm / 14mm	H1 35mm	H1/H2 15mm / 15mm	H1/H2 20mm / 20mm
大舵角	H1/H2 20mm / 20mm	H1 55mm	H1/H2 22mm / 22mm	H1/H2 30mm / 30mm

电机不工作	A) 电池电量耗尽	A) 充电
	B) 发射机电量耗尽	B) 更换或者充电
	C) 发射机开关没开	C) 打开发射机开关
	D) 电池没有连接好	D) 检查并连接好电池
	E) 电机连接错误	E) 检查并正确连接电机
	F) 因为摔机等原因损坏	F) 更换
	G) 其它或者ESC故障	G) 检查ESC或者经销商
飞机难以控制	A) 飞行中遇到强风或者乱流	A) 无风的时候起飞
	B) 电池电量耗尽	B) 需要充电
	C) 发射机电量耗尽	C) 更换电池或者给电池充电
	D) 发射机天线没有完全展开	D) 展开发射机天线
	E) 舵面的控制过量	E) 使用小舵量进行飞行
飞行时机头一直向下，需要补偿升舵	A) 重心靠前	A) 参考说明书，向后调整重心
在没有控制发射机时，飞机总是向上、向下；或者飞机总是向左、向右倾斜	A) 没有对升降舵、副翼进行微调	A) 适当调节一些微调
	B) 飞行时遇到太大的自然风力	B) 先降落，选择无风天气飞行
飞行时升降舵异常灵敏，俯、仰不安定	A) 重心靠后	A) 参考说明书，向前调整重心
地面滑跑时方向会偏	A) 前轮没有居中	A) 居中前轮
	B) 方向舵没有居中	B) 居中方向舵
起飞困难	A) 油门没有推到最大	A) 油门推到最大
	B) 滑跑助飞距离不够	B) 尽可能滑跑得更远些
	C) 升舵舵量不够	C) 使用更大的舵量
飞机爬升困难	A) 电池电量不足	A) 需要重新充电
	B) 涵道风扇损坏	B) 确认并重新更换
	C) 电机损坏	C) 确认并重新更换
	D) 电调过热保护，功率降低	D) 先降落，确认并选择更大功率的电调
电流充电后发热	A) 电池充电时，会产生热量，这是正常的	A) 电流充电后，会发热，但用手触摸不烫
电机震动	A) 涵道风扇损坏	A) 确认并更换
	B) 马达损坏	B) 确认并更换
	C) 涵道需要调节动平衡	C) 调节动平衡
	D) 高速运转时，可能产生轻微震动	D) 轻微震动是正常的，可以使用
控制面向错误的方向运动	A) 舵机方向装反	A) 重新安装舵机

产品编号	配件名称	规格参数	单位	数量	产品编号	配件名称	规格参数	单位	数量
E721	90mm 涵道动力组	90mm 涵道风扇组	套	1	FJ3051089	后起落架轮轴	后起落架轮轴	根	1
		3748 -1450KV 无刷电机	个	1			机米螺丝 M4*4	颗	1
		螺丝 PWA3*12	颗	6	FJ3051091	起落架舱门盖	前起落架舱门盖	套	1
P0902	90mm 涵道风扇组	12叶金属90mm涵道	套	1			后起落架舱门盖	套	1
M003711	电机	3748 -1450KV 无刷电机	个	1			螺丝 PM4*5	颗	2
FE0101	电调	100A ESC	个	1	FJ3051092	Stinger90专用塑料件	/	套	1
MA30172	舵机	17g全金属舵机 (正旋)	个	1	N204	钢丝塑料扣	/	个	6
MA30172R	舵机	17g全金属舵机 (反旋)	个	1	N102	舵面摇臂	塑料舵面摇臂	个	7
MA30098	舵机	9g全金属舵机 (反旋)	个	1			金属球头	个	7
FB65035	电池	6S 22.2V 5000mAh 35C	组	1	FJ305111	舵面控制钢丝	主翼舵机控制钢丝 (含球头扣)	根	2
E22	起落架舱门控制板	V2版盒装	套	1			襟翼舵机控制钢丝 (含球头扣)	根	2
E01	LED灯控制板	V3版盒装 最高支持5W功率 LED灯珠	套	1			平尾舵机控制钢丝 (含球头扣)	根	2
E51	3轴平衡仪	3轴平衡仪 (盒装,飞行辅助系统)	套	1			方向舵机控制钢丝 (含球头扣)	根	1
FJ305101	机身套件	/	套	1			前轮舱门舵机控制钢丝 (含球头扣)	根	2
FJ305102	主翼套件	/	套	1			前轮转向舵机控制钢丝 (含球头扣)	根	1
FJ305103	平尾	/	套	1	N205	金属球头	金属球头	颗	8
FJ305104	垂尾	/	套	1	N206	塑料球头扣	塑料球头扣	个	8
FJ305105	机头罩	/	个	1	N303	襟翼单向活页	/	套	8
FJ305106	座舱	/	套	1	N901	特殊舵机摇臂	使用于前轮转向舵机摆臂	套	2
12680	飞行员	/	个	1	FJ305112	Stinger 90 专用螺丝包	螺丝 FM2*10	颗	7
FJ305108	起落架套件	/	套	1			螺丝 PM3*40	颗	4
FJ3051081	前起落架	完成品,可直接使用	个	1			螺丝 M3*14	颗	1
FJ3051901	LED滑行灯	LED滑行灯	套	1			螺丝 PM4*5	颗	2
		螺丝 PWM3*6	颗	1			螺丝 PM3*6	颗	1
FJ3051902	LED灯珠	5W	颗	2			螺丝 PM2*3	颗	1
FJ3051903	LED灯罩	LED灯罩	套	1			螺丝 PM2*4	颗	3
		LED灯座	套	1			螺丝 PWM3*8	颗	3
		螺丝 PWM3*6	颗	1			螺丝 PWA3*12	颗	10
FJ3051082	前起落架转向摇臂	/	个	1			螺丝 PWA3*8	颗	2
FJ3051083	前起落架钢丝	前起落架主钢丝	根	1			螺丝 PWA2*8	颗	10
		E型扣 2.0	片	1			螺母 M2	颗	7
		螺丝 PT2.6*6	颗	1			螺丝 PWA1.7*5	颗	14
		机米螺丝 M4*4	颗	2			螺丝 KA3*12	颗	8
FJ3051084	前起落架减震组	前起落架减震组 (组装完成)	套	1	螺丝 PA3*25	颗	10		
		螺丝 PM2*3	颗	1	螺丝 PT2.6*6	颗	1		
		螺丝 PM2*4	颗	1	螺丝 M3*6	颗	4		
		机米螺丝 M4*4	颗	2	螺丝 M3*10	颗	1		
		机米螺丝 M3*5	颗	1	螺丝 M4*4	颗	6		
FJ3051085	前起落架轮轴	前起落架轮轴	根	1	螺丝 M3*5	颗	5		
		机米螺丝 M3*3	颗	1	螺丝 M3*3	颗	3		
		机米螺丝 M3*5	颗	1					
FJ3051086L	后起落架(左)	完成品,可直接使用	个	1					
FJ3051086R	后起落架(右)	完成品,可直接使用	个	1					
FJ3051087	后起落架钢丝	后起落架钢丝	根	1					
		机米螺丝 M3*5	颗	2					
		机米螺丝 M4*4	颗	2					
FJ3051088	后起落架减震组	后起落架减震组 (组装完成)	套	1					
		机米螺丝 M4*4	颗	3					



Freewing Model Co.,Ltd

<http://www.freewing-model.com>