

# L-39 ALBATROS USER MANUAL

1/9 scale 80mm EDF Jet

Wingspan: 1053mm    Length: 1351mm    Empty Weight: 2200g (w/o Battery)



EN	1-9
中	10-19

- 1 Introduction
- 2 Basic Product Information
- 2 Package List
- PNP Assembly Instructions**
- 3 Traction steel wire use instruction
- 3 Install Fuselage
- 3 Install Horizontal Stabilizer
- 3 Install Vertical Stabilizer
- 4 Install Main wing
- 4 Install drop tank
- 4 Install Scale Accessories
- 5 Pushrod instructions
- 5 Control board connection diagram
- 6 Battery Size
- 6 Center of Gravity
- 7 Control Direction Test
- 8 Dual Rates and Flight Attention
- 9 Servo Direction
- 9 Motor Specification

- 10 前言
- 11 产品基本参数
- 11 产品包装清单
- PNP组装说明**
- 12 牵引钢丝使用说明
- 12 机身组装
- 12 平尾组装
- 12 垂尾组装
- 13 主翼组装
- 13 副油箱组装
- 13 仿真小配件
- 14 舵面控制钢丝尺寸
- 14 集线板安装说明
- 15 电池安装说明
- 15 重心示意图
- 16 舵面测试
- 17 大、小舵参数及飞行注意事项
- 18 舵机使用说明
- 19 电机参数

Combining the sport performance of the Avanti and the fidelity of scale aircraft like the A-4 and MiG-21, Freewing model continues the legacy of its excellent performing 80mm EDF jets with its Freewing 80mm L-39C/Z Albatros! Developed originally by Aero Vodochody in the 1960s in what is now the Czech Republic, the Aero L-39 Albatros excelled as a jet trainer platform with its powerful turbofan and overall reliability. The L-39 and its successive variants continues in service throughout the world in militaries as trainers and light attack platforms, and in civil aviation including aerial demo teams and racing.

The Freewing L-39 Albatros is the largest and most capable production PNP L-39 in the world. Optimized for high maneuverability and precision flying, the L-39 truly is a "Sport jet wearing Scale jet clothing". The Standard Version uses a powerful 3530-1850kv brushless motor and 100A ESC to power the 12 blade 80mm EDF. A Deluxe Version upgrades the motor to a 3658-1857kv inrunner for higher power output.

The Freewing L-39 Albatros includes grass capable suspension landing gear, a full coverage nose door, scale wingtip lights, and easily removable tip tanks, ordnance, belly gun pod, and wings. Only one joint is required to complete the model's general assembly. A plastic lined cockpit also resists deformation under sunlight, and optional 3D Printed cockpit detail upgrade parts are also sold separately.

### Note

1. This is not a toy! Operator should have a certain experience, beginners should operate under the guidance of professional players.
2. Before install, please read through the instructions carefully and operate strictly under instructions.
3. Cause of wrong operation, Freewing and its vendors will not be held responsible for any losses.
4. Model planes' players must be on the age of 14 years old.
5. This plane used the EPO material with surface spray paint, don't use chemical to clean, otherwise it will damage.
6. You should be careful to avoid flying in areas such as public places, high-voltage-intensive areas, near the highway, near the airport or any other place where laws and regulation clearly prohibit.
7. You cannot fly in bad weather conditions such as thunderstorms, snows....
8. Model plane's battery, don't allowed to put in everywhere. Storage must ensure that there is no inflammable and explosive materials in the round of 2M range.
9. Damaged or scrap battery should be properly recycled, it can't discard to avoid spontaneous combustion and fire.
10. In flying field, the waste after flying should be properly handled, it can't be abandoned or burned.
11. In any case, you must ensure that the throttle is in the low position and transmitter switch on, then it can connect the lipo-battery in aircraft.
12. Do not try to take planes by hand when flying or slow landing process. You must wait for landing stop, then carry it.



**Warning:** This is not a toy. Not for children under 14 years. Young people under the age of 14 should only be permitted to operate this model under the instruction and supervision of an adult. Please keep these instructions for further reference after completing model assembly.

## Product basic information

EN

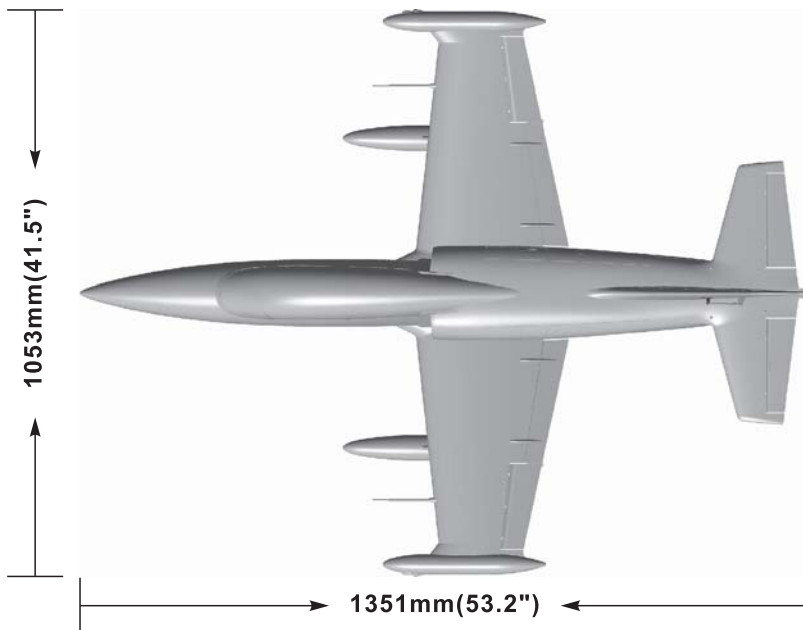

### Standard Version

Wingload : 142g/dm<sup>2</sup>  
 Motor: 3530-1850KV O/R Motor  
 Servo: 9g MG Digital servo (8pcs)  
 ESC: 100A with 5A BEC  
 Ducted fan: 80mm 12-blade fan  
 Weight: 2200g (w/o Battery)  
 Thrust: 3350g

### Deluxe Version

Wingload : 144g/dm<sup>2</sup>  
 Motor: 3658-1857KV I/R Motor  
 Servo: 9g MG Digital servo (8pcs)  
 ESC: 100A with 8A UBEC  
 Ducted fan: 80mm 12-blade fan  
 Weight: 2250g (w/o Battery)  
 Thrust: 3700g

### General function

- Material: EPO
- Retract landing gear controlled
- Front landing gear cabin door
- Scale high LED light set
- New aluminum shock absorber landing gear
- Scale cockpit, pilot

**⚠ Note:** The parameters in here are derived from test result using our accessories. If use other accessories, the test result will be different. Any problem since of using other accessories, we are not able to provide technical support.

## Package list



Different equipment include different spareparts. Please refer to the following contents to check your sparepart list.

No.	Name	PNP	ARF Plus	Airframe	No.	Name	PNP	ARF Plus	Airframe
1	Fuselage	Pre-installed all electronic parts	Pre-installed servo	No electronic equipment	6	Carbon tube	✓	✓	✓
2	Main wing	Pre-installed all electronic parts	Pre-installed servo	No electronic equipment	7	Pushrod instructions	✓	✓	✓
3	Horizontal tail	Pre-installed all electronic parts	Pre-installed servo	No electronic equipment	8	Non-slip mat & Glue	✓	✓	✓
4	Vertical tail	Pre-installed all electronic parts	Pre-installed servo	No electronic equipment	9	Manual	✓	✓	✓
5	Drop tank	✓	✓	✓	10	Screw	✓	✓	✓

**Traction steel wire use instruction**

Through investigation, excessive servo extension line will increase the risk of poor contact joints, and lead to the servo outages caused flight accidents. Because of L-39 large and flat trough interior space, we don't use the servo extension wire in this jet. As the below photo shown, package includes a traction steel wire, we can use it to pull the main wing/elevator/rudder servo cables to the battery compartment.

**Install fuselage**

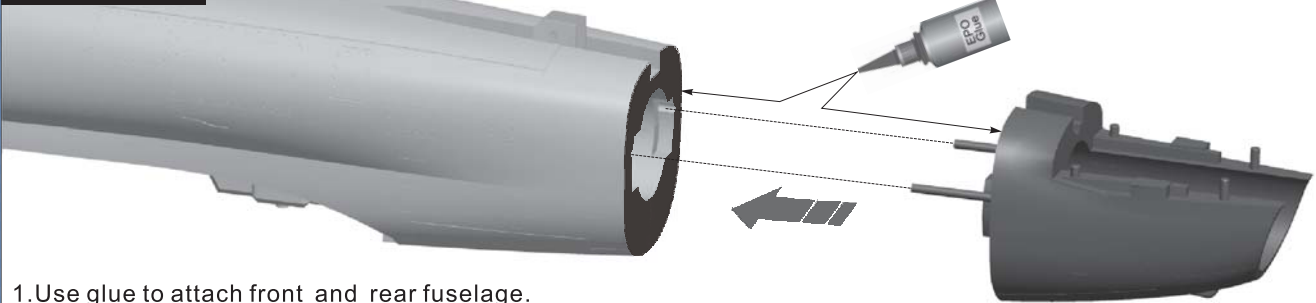

1. Use glue to attach front and rear fuselage.

**Install horizontal tail**

1. Use 4 screw to fix the horizontal tail.
2. Use traction steel wire to pull the horizontal tail servo wire to the battery compartment.

- A- Horizontal tail
- B- Screw (FA3x8mm 4pcs)
- C- Servo wire

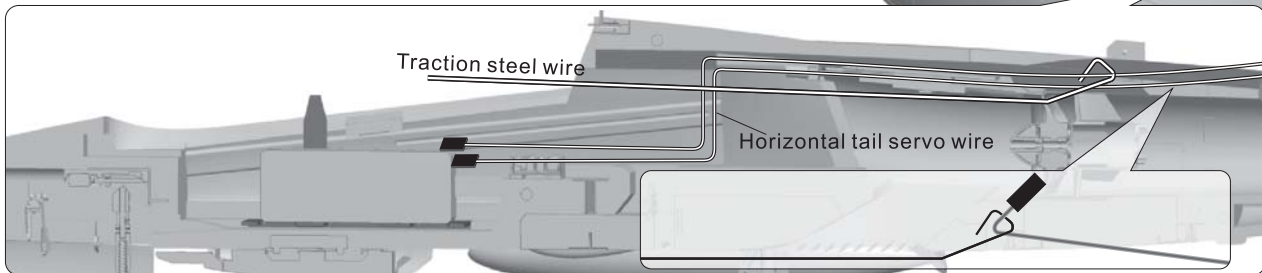
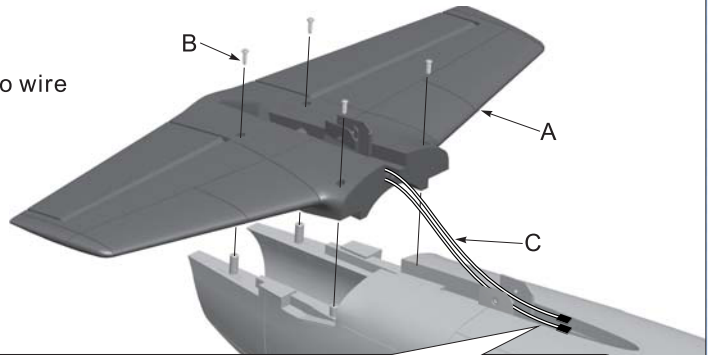

**Install vertical tail**

1. Use traction steel wire to pull the rudder servo wire to the battery compartment.
2. Use 4 screw to fix the vertical tail.

- A- Vertical tail
- B- Screw (FA3x8mm 4pcs)
- C- Rudder servo wire

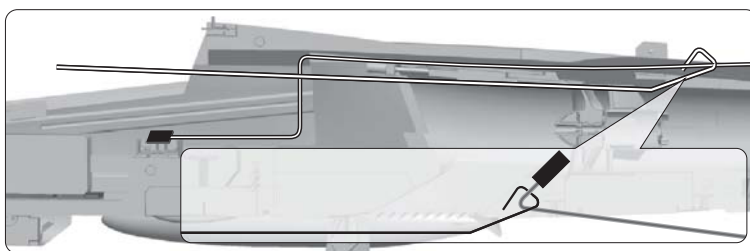
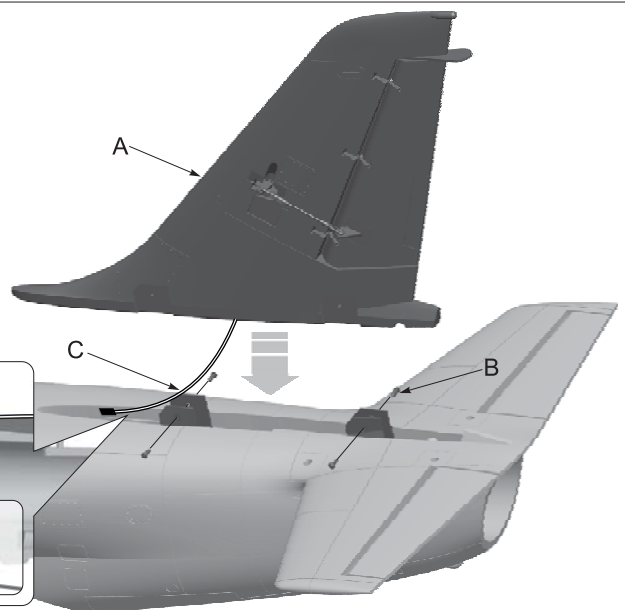

**Install main wing**

As the photo shown:  
 1. Use Ribbon wire to insert the main wing control board  
 2. Install the main wing at the bottom of fuselage, then use 4pcs screws to fix it.

- A- Main wing control board
- B- Ribbon wire
- C- Main wing
- D- Screw (PM3X8mm 4PCS)

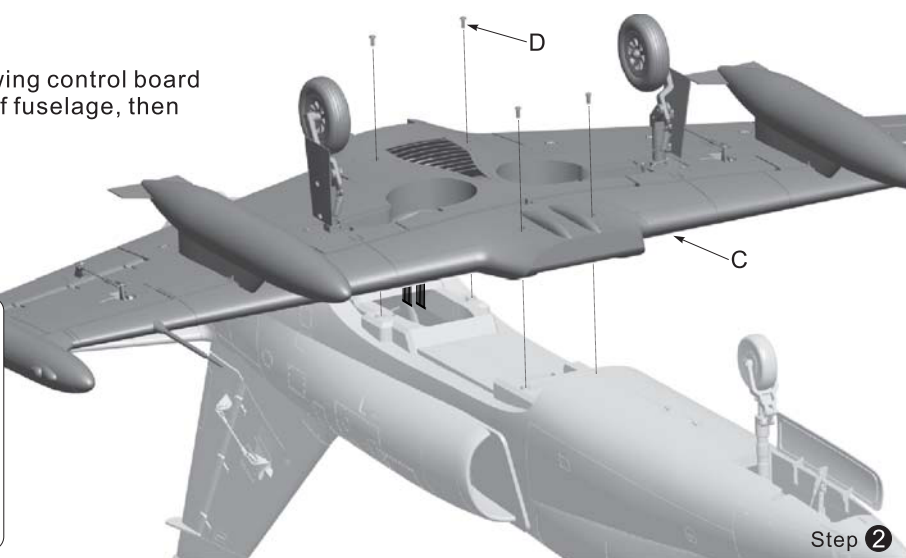
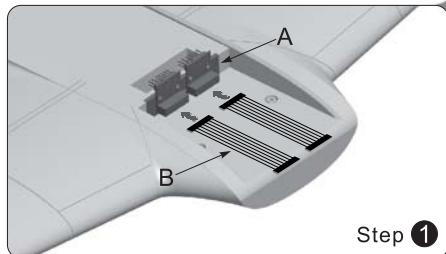

**Install drop tank**

Refer to the right photo, installed the LED light and drop tank.

- A- Screw (FA3X8mm 4PCS)
- B- LED light extension wire
- C- LED wire

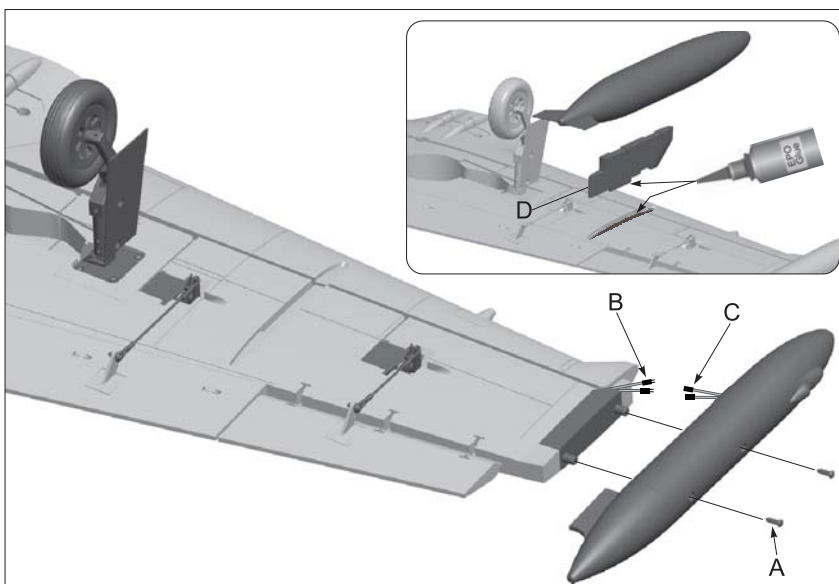

**Install small plastic parts**

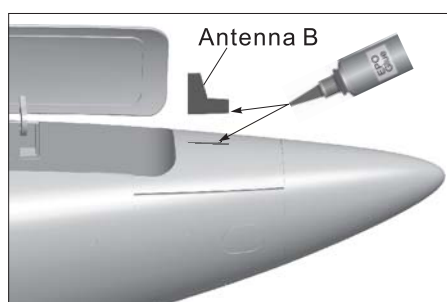
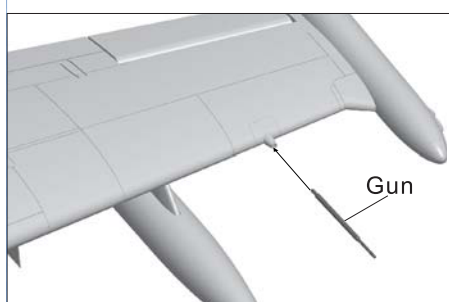
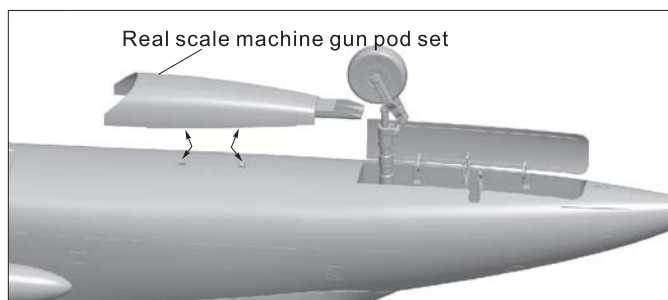
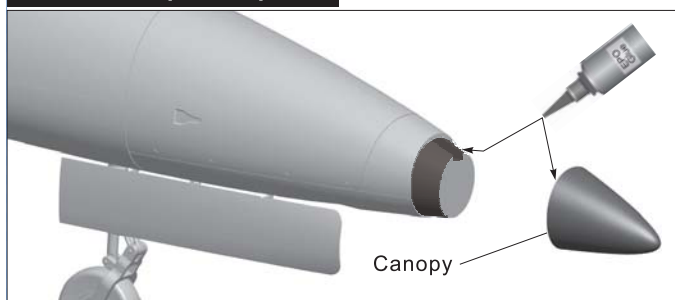

**Pushrod instructions**

<p><b>Nose steering pushrod size</b></p> <p>75mm (2-15/16")</p> <p>Pushrod diameter : Ø 1.2mm</p>	<p><b>Servo pushrod installing hole</b></p>
<p><b>Nose cabin door pushrod size</b></p> <p>32mm (1-1/4")</p> <p>Pushrod diameter : Ø 1.0mm</p>	<p><b>Servo pushrod installing hole</b></p>
<p><b>Flap pushrod length</b></p> <p>80mm (3-1/8")</p> <p>Pushrod diameter : Ø 1.5mm</p>	<p><b>Flap pushrod mounting hole</b></p>
<p><b>Aileron pushrod length</b></p> <p>66mm (2-5/8")</p> <p>Pushrod diameter : Ø 1.5mm</p>	<p><b>Aileron pushrod mounting hole</b></p>
<p><b>Elevator pushrod length</b></p> <p>58mm (2-1/4")</p> <p>Pushrod diameter : Ø 1.5mm</p>	<p><b>Elevator pushrod mounting hole</b></p>
<p><b>Rudder pushrod length</b></p> <p>63mm (2-1/2")</p> <p>Pushrod diameter : Ø 1.5mm</p>	<p><b>Rudder pushrod mounting hole</b></p>

**Multifunction control box (MCB-E)**

L-39 model plane use control board (Item No: E1712) to reduce connection wires, its more convenience to use the neat clear equipment compartment. For the specific functions and usage of control box, please refer to the manual of 《Multifunction control box(MCB-E)》.

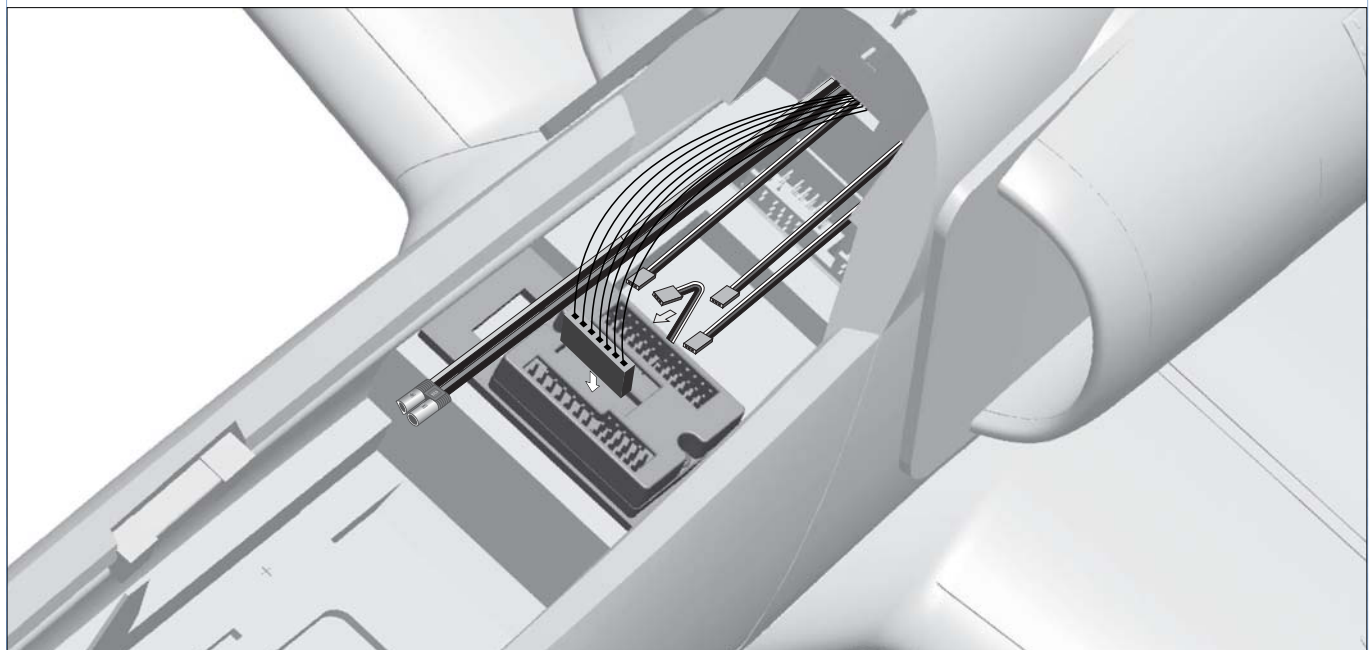

## Battery Size

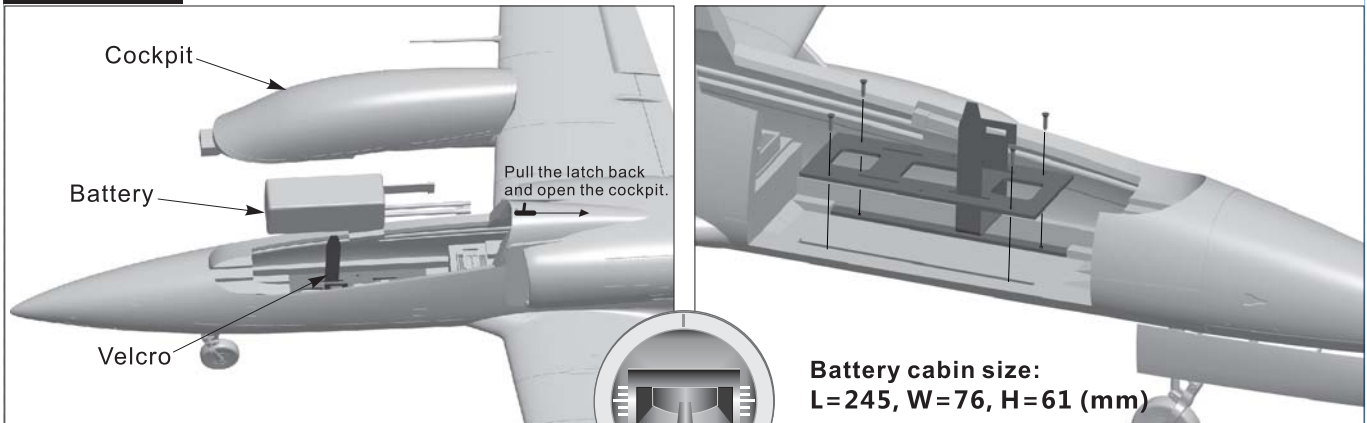

**Battery cabin size:**  
**L=245, W=76, H=61 (mm)**

Before connecting the battery and receiver, please switch on the transmitter power and make sure the throttle stick is in the lowest position. Bind your receiver to your transmitter according to your transmitter's instruction manual.

We recommend the following LiPo battery:  
**6S 22.2V 4000mAh ~ 6S 22.2V 5000mAh(1pcs)**  
**Discharge rate of C ≥35C**

## Center of Gravity

Correct Center of Gravity (CG) is critical for enabling safe aircraft stability and responsive control. Please refer to the following CG diagram to adjust your aircraft's Center of Gravity.

- Depending on the capacity and weight of your chosen flight batteries, move the battery forward or backward to adjust the Center of Gravity.
- If you cannot obtain the recommended CG by moving the battery to a suitable location, you can also install a counterweight to achieve correct CG. However, with the recommended battery size, a counterweight is not required. We recommend flying without unnecessary counterweight.

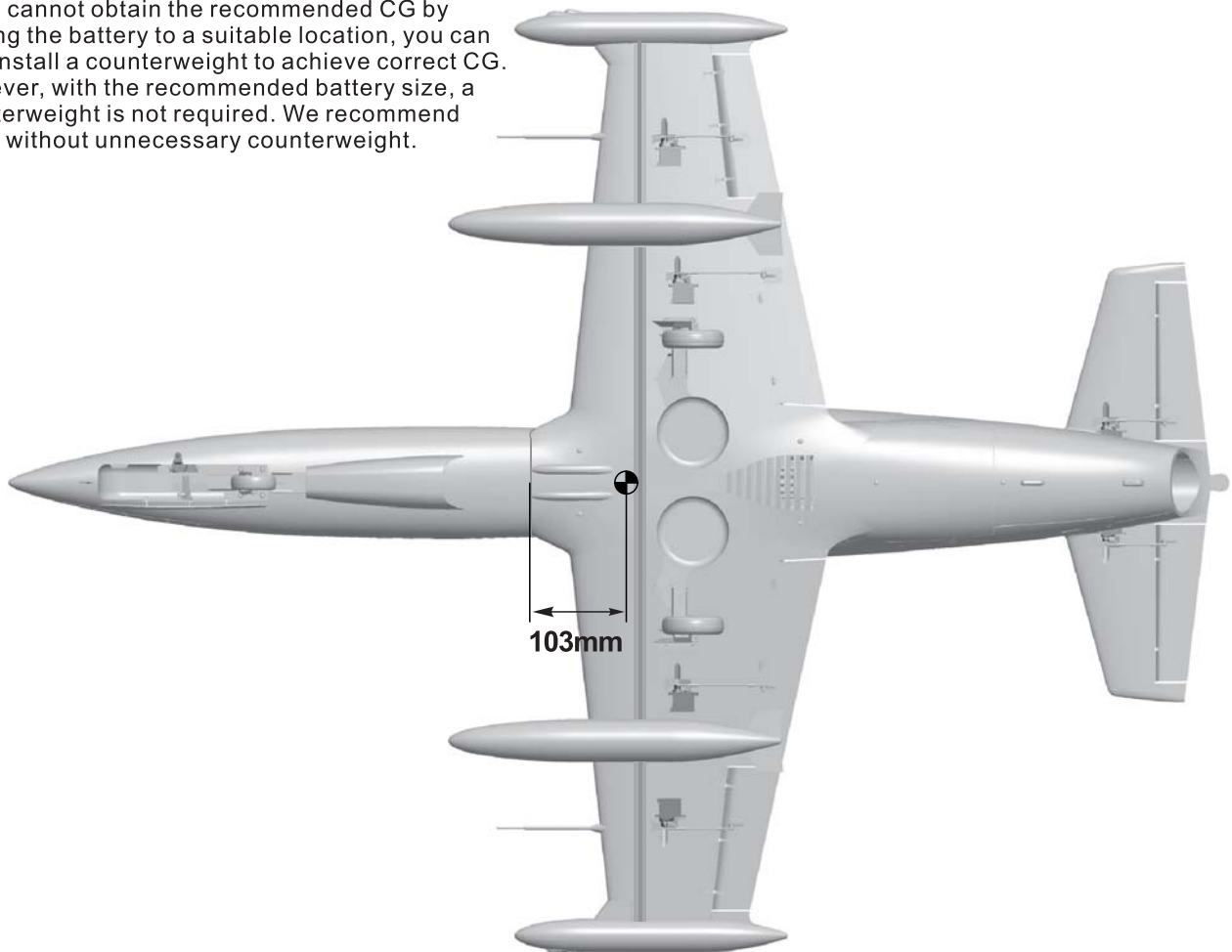



## Control Direction Test

After installed the plane, before flying, we need a fully charged battery and connect to the ESC, then use radio to test and check that every control surface work properly.

### Aileron

Stick Left



Stick Right



### Elevator

Stick down

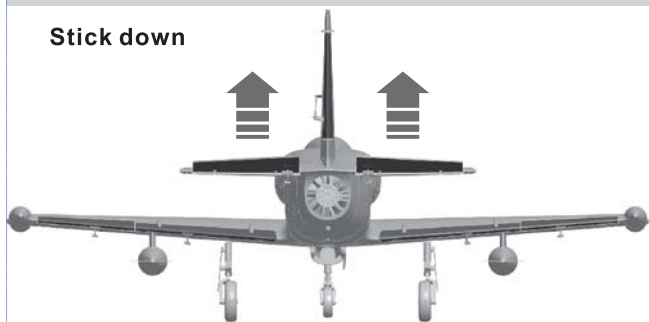

Stick Up



### Rudder

Stick Left

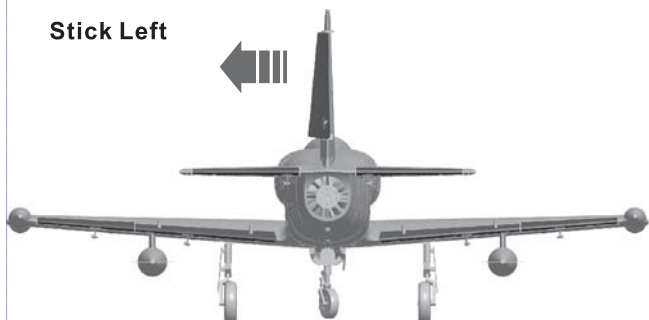

Stick Right

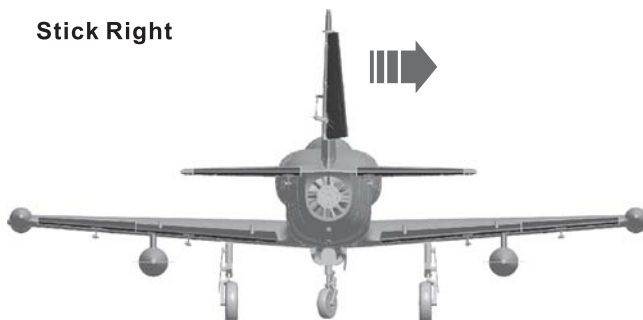

### Flap

Flap down

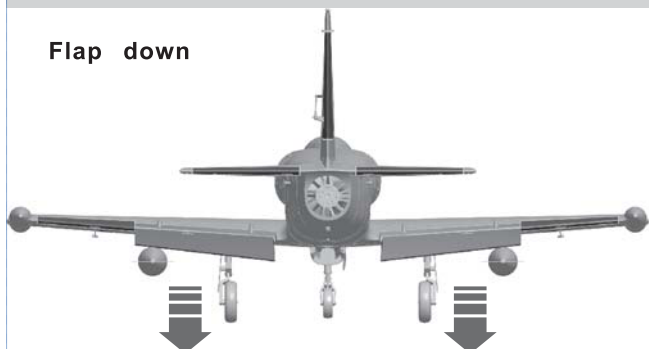

## Dual Rates

According to our testing experience, use the following parameters to set Aileron/Elevator Rate. Program your preferred Exponential % in your radio transmitter. We recommend using High Rate for the first flight, and switching to Low Rate if you desire a lower sensitivity. On successive flights, adjust the Rates and Expo to suit your preference.

### Aileron

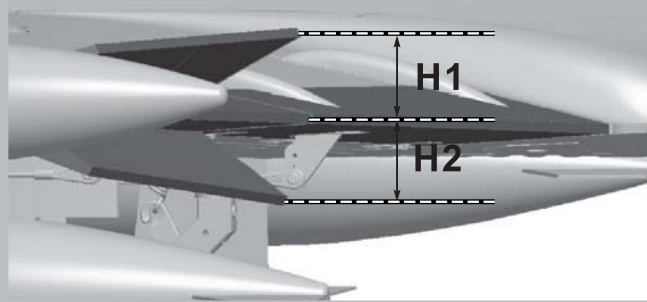

### Flaps

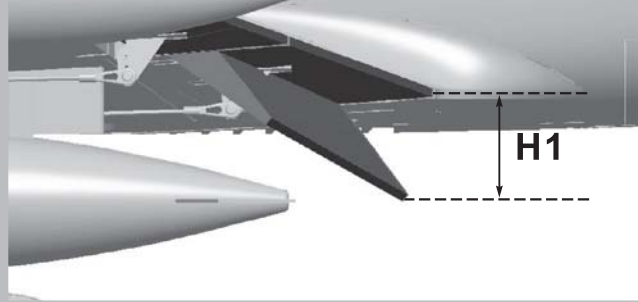

### Elevator

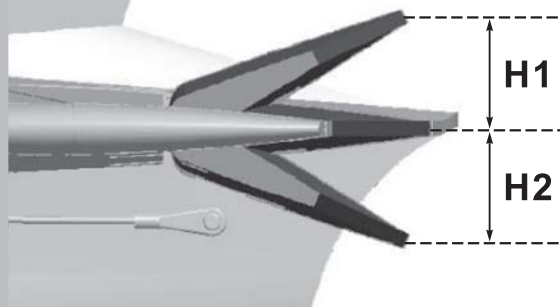

### Rudder

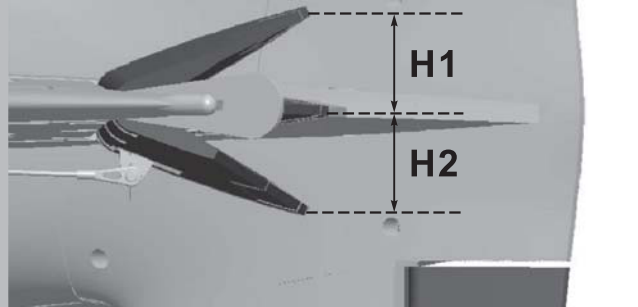

	Aileron(measured closest to the fuselage)	Elevator(measured closest to the fuselage)	Rudder(Measured from the bottom)	Flaps
<b>Low Rate</b>	H1/H2 17mm/17mm D/R Rate : 80%	H1/H2 19mm/19mm D/R Rate : 80%	H1/H2 27mm/27mm D/R Rate : 80%	H1 19mm
<b>High Rate</b>	H1/H2 21mm/21mm D/R Rate : 100%	H1/H2 26mm/26mm D/R Rate : 100%	H1/H2 35mm/35mm D/R Rate : 100%	H1 29mm

### ⚠ Important Flight Notes:

A Flap-to-Elevator Mix is required to maintain level flight when the flaps are deployed. The detail is as below:

**With high rate flaps deployed, mix 1.5mm of DOWN elevator.**

**With low rate flaps deployed, mix 1.0mm of DOWN elevator.**

# Pre-Installed Component Overview

EN

## Servo Direction

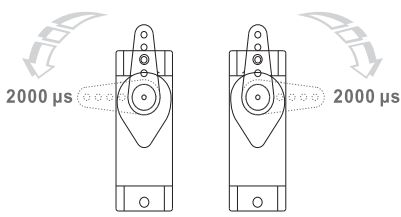

The servo positive or reverse rotation is defined as follows:  
 When servo input signal change from 1000μs to 2000μs,  
 The servo arm is rotated clockwise, its positive servo.  
 The servo arm is rotated counterclockwise, its reverse servo.

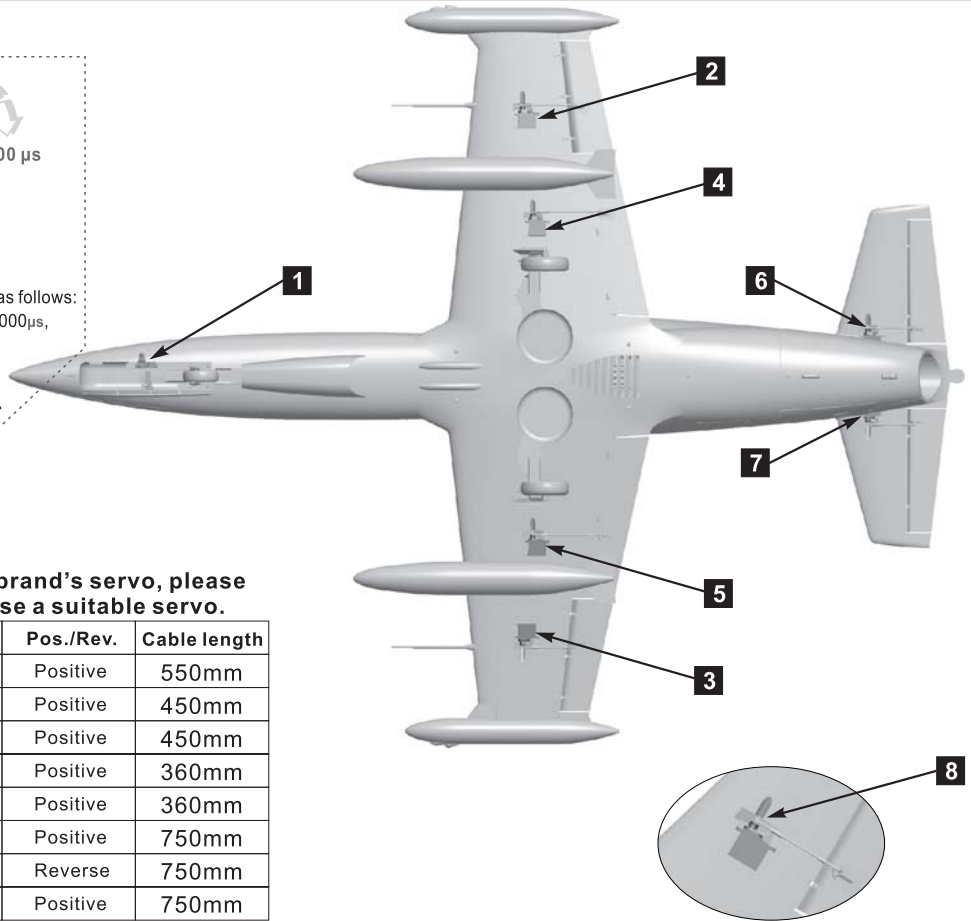

If you need to purchase another brand's servo, please refer to the following list to choose a suitable servo.

Position	Servo type	No.	Pos./Rev.	Cable length
Nose gear steering servo	9g MG-Digital	1	Positive	550mm
Aileron(L)	9g MG-Digital	2	Positive	450mm
Aileron(R)	9g MG-Digital	3	Positive	450mm
Flap(L)	9g MG-Digital	4	Positive	360mm
Flap(R)	9g MG-Digital	5	Positive	360mm
Elevator(L)	9g MG-Digital	6	Positive	750mm
Elevator(R)	9g MG-Digital	7	Reverse	750mm
Rudder	9g MG-Digital	8	Positive	750mm

## Motor Specification

### MO035304 3530-1850KV

Use for 6S  
Standard Version

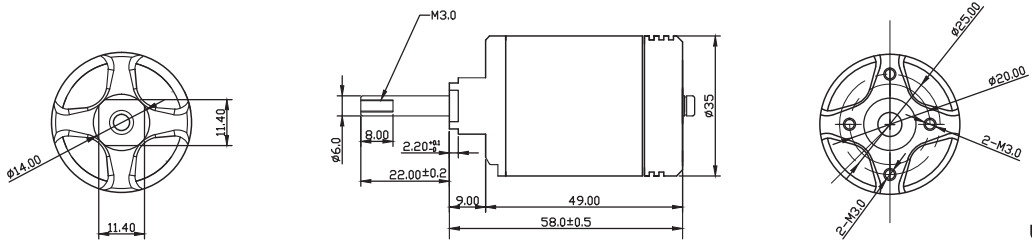

Unit :mm

### MI036582 3658-1857KV

Use for 6S  
Deluxe Version

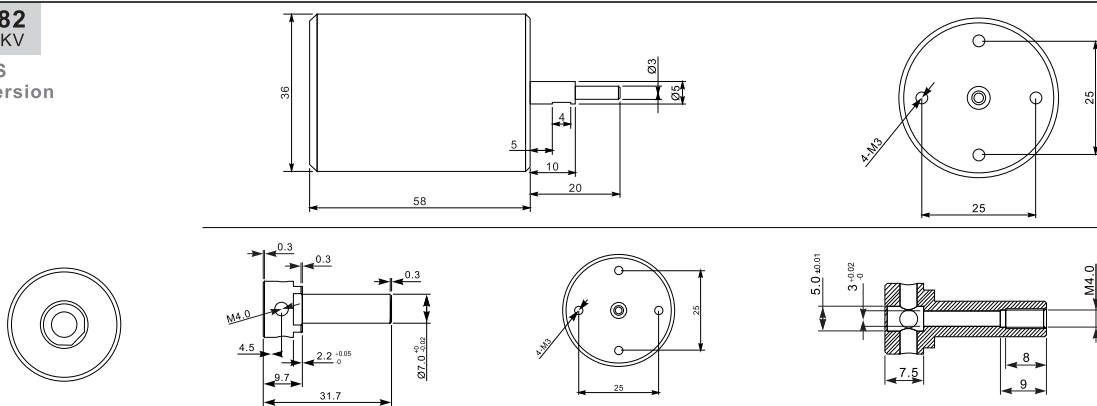

Unit :mm

Item No.	Motor size	Motor(KV)	Thrust(g)	Current(A)	Use voltage (V)	Use ESC (A)	EDF Weight (g)	Max power (W)	Efficiency (g/w)
E7239	MO035304 3530-1850KV	1850	3350	90	22.2(6S)	100	318	2000	1.67
E72392	MI036582 3658-1857KV	1857	3700-3800	95-105	22.2(6S)	130	370	2200	1.7

[www.freewing-model.com](http://www.freewing-model.com)